

Name: _____		Date: _____		Event: _____	
City: _____		State: _____		Track: _____	
Track Conditions	<input type="checkbox"/> Indoor	<input type="checkbox"/> Tight	<input type="checkbox"/> Smooth	<input type="checkbox"/> Hard Packed	<input type="checkbox"/> Blue Groove
	<input type="checkbox"/> Outdoor	<input type="checkbox"/> Open	<input type="checkbox"/> Rough	<input type="checkbox"/> Loose/Loamy	<input type="checkbox"/> Dry
				<input type="checkbox"/> Wet	<input type="checkbox"/> Grass
				<input type="checkbox"/> Dusty	<input type="checkbox"/> Astro Turf
					<input type="checkbox"/> Low Bite
					<input type="checkbox"/> High Bite
					<input type="checkbox"/> Med Bite
					<input type="checkbox"/> Other _____

**FRONT SUSPENSION**

Toe: \_\_\_\_\_

Ride Height: \_\_\_\_\_

Camber: \_\_\_\_\_

Caster: 10° 12.5° 15° 20°

Diff. Type: Ball Gear Setting/Oil: \_\_\_\_\_

Driveshaft Type: CVA Universal

Front Drive: Full-Time 4WD Clicker: \_\_\_\_\_

Sway Bar: None White Yellow Pink

Oil: \_\_\_\_\_

Piston: \_\_\_\_\_

Spring: Standard Low Freq. Color: \_\_\_\_\_

Shock Limiters: \_\_\_\_\_ Stroke: \_\_\_\_\_

Shock Location: \_\_\_\_\_

Bump Steer Ball Stud: Standard Low Mount

Bumper Steer Spacers: \_\_\_\_\_

Camber Link: \_\_\_\_\_

Ackermann: A B Adjustable: \_\_\_\_\_

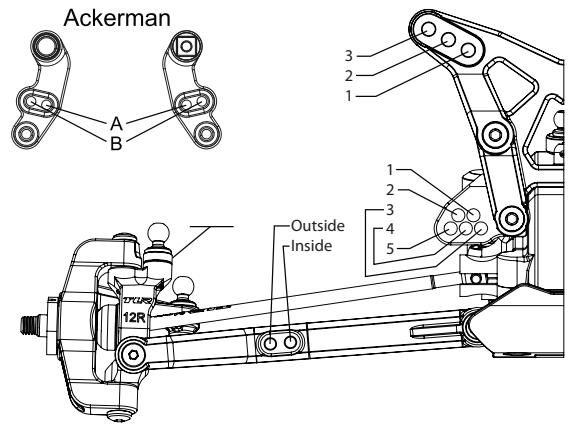

Notes: \_\_\_\_\_

**REAR SUSPENSION**

Toe: 2.0° 2.5° 3.0°

Anti-Squat: 1° 2° 2.5° 3°

Roll Center: Low Roll Center (LRC) High Roll Center (HRC)

Ride Height: \_\_\_\_\_

Camber: \_\_\_\_\_

Diff. Type: Ball Gear Setting/Oil: \_\_\_\_\_

Driveshaft Type: CVA Universal

Rear Hub Spacing: \_\_\_\_\_

Hex Width: \_\_\_\_\_

Sway Bar: None White Yellow Pink

Oil: \_\_\_\_\_

Piston: \_\_\_\_\_

Spring: Standard Low Freq. Color: \_\_\_\_\_

Shock Limiters: \_\_\_\_\_ Stroke: \_\_\_\_\_

Camber Link: \_\_\_\_\_

Shock Locations: \_\_\_\_\_

Wing/Wickerbill: \_\_\_\_\_

Battery Type: Shorty Saddles

Battery Position: \_\_\_\_\_

Rear Suspension: 22 Hub/Hex 22-4 Hub/Hex

Rear Shock Orientation: Front of Arm Rear of Arm

**ELECTRONICS**

Radio: \_\_\_\_\_ Timing Advance: \_\_\_\_\_

Servo: \_\_\_\_\_ Throttle/Brake Expo: \_\_\_\_\_

ESC: \_\_\_\_\_ Servo Expo: \_\_\_\_\_

Initial Brake: \_\_\_\_\_ Throttle/Brake EPA: \_\_\_\_\_

Drag Brake: \_\_\_\_\_ Motor: \_\_\_\_\_

Throttle Profile: \_\_\_\_\_ Pinion: \_\_\_\_\_ Spur: \_\_\_\_\_

Battery: \_\_\_\_\_

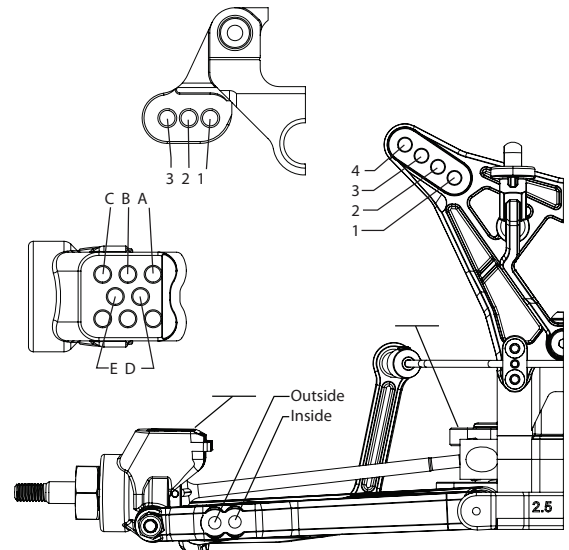

Notes: \_\_\_\_\_

TIRES	Compound	Insert	Additive	NOTES
Front: _____				
Rear: _____				