

| | |
|--------------------------|--------------------------|
| Name: _____ | Date: _____ Event: _____ |
| City: _____ State: _____ | Track: _____ |

| | |
|--|--|
| Track Conditions: <input type="checkbox"/> Indoor <input type="checkbox"/> Tight <input type="checkbox"/> Smooth <input type="checkbox"/> Hard Packed <input type="checkbox"/> Blue Groove <input type="checkbox"/> Wet <input type="checkbox"/> Grass <input type="checkbox"/> Low Bite <input type="checkbox"/> High Bite <input type="checkbox"/> Outdoor <input type="checkbox"/> Open <input type="checkbox"/> Rough <input type="checkbox"/> Loose/Loamy <input type="checkbox"/> Dry <input type="checkbox"/> Dusty <input type="checkbox"/> Astro Turf <input type="checkbox"/> Med Bite <input type="checkbox"/> Other _____ | |
|--|--|

Front Suspension

Toe: _____
 Ride Height: _____ Camber: _____
 Caster: 0° 5°
 Kick Angle: 20° 25° 30°
 VLA Setting: Short Arm Long Arm
 Oil: _____
 Piston: _____
 Spring: Standard Low Freq. Color: _____
 Front Pivot: Aluminum Plastic HRC
 Kick Shim: Brass Plastic
 Shock Limiters: _____ Stroke: _____
 Shock Location: _____
 Steering Type: Slide Rack Bell Cranks
 Spindle Ball Stud: Standard Low Mount
 Bumper Steer Spacers: _____
 Ackermann Ball Stud: Standard Low Mount
 Ackermann Spacers: _____
 Camber Link: _____

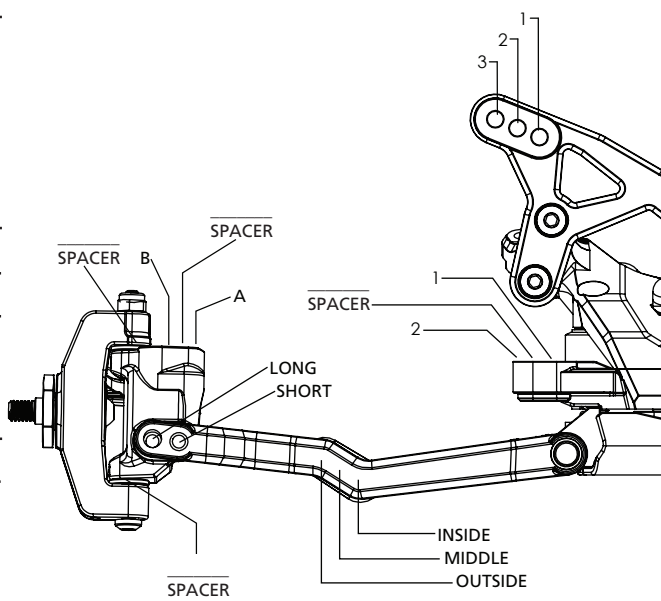

Notes: _____

Rear Suspension

Transmission Type: 3-Gear 4-Gear
 Toe Inserts: 0.5° 1° 1.5° 2° 2.5° 3° 3.5° 4°
 Anti-Squat Inserts: 0° .5° 1° 1.5° 2° 2.5° 3°
 Roll Center: Low Roll Center (LRC) High Roll Center (HRC)
 Ride Height: _____ Camber: _____
 Rear Hub Spacing: _____
 Hex Width: _____
 Sway Bar: _____
 Oil: _____
 Piston: _____
 Spring: Standard Low Freq. Color: _____
 Shock Limiters: _____ Stroke: _____
 Shock Location: _____
 Inner Link Spacer: -1mm 0mm +1mm
 Camber Link: _____
 Wing/Wickerbill: _____
 Battery Position: _____

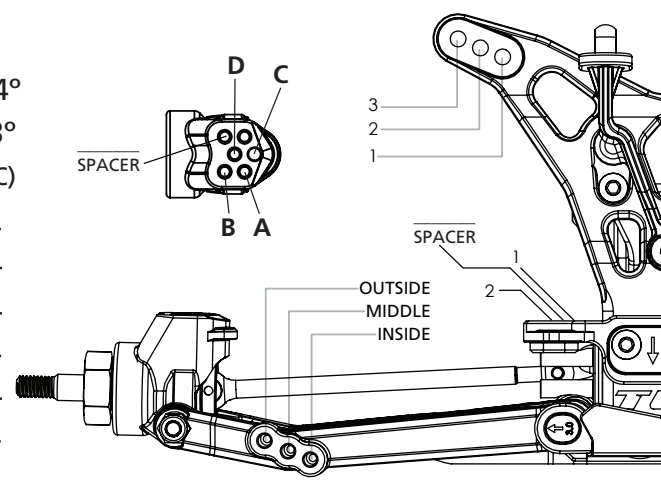

Electronics

| | |
|-------------------------|----------------------------|
| Radio: _____ | Timing Advance: _____ |
| Servo: _____ | Throttle/Brake Expo: _____ |
| ESC: _____ | Servo Expo: _____ |
| Initial Brake: _____ | Throttle/Brake EPA: _____ |
| Drag Brake: _____ | Motor: _____ |
| Throttle Profile: _____ | Pinion: _____ Spur: _____ |
| | Battery: _____ |

| | | | | |
|--|--|----------------------------|--------------------------|----------------------------|
| Weight Placement (Mark with "X") Weight of each piece _____ oz./g | Tires Front: _____ Rear: _____ Notes: _____ | Compound _____ _____ | Insert _____ _____ | Additive _____ _____ |
|--|--|----------------------------|--------------------------|----------------------------|