

Name: _____		Date: _____		Event: _____	
City: _____		State: _____		Track: _____	
Track Conditions	<input type="checkbox"/> Indoor	<input type="checkbox"/> Tight	<input type="checkbox"/> Smooth	<input type="checkbox"/> Hard Packed	<input type="checkbox"/> Blue Groove
	<input type="checkbox"/> Outdoor	<input type="checkbox"/> Open	<input type="checkbox"/> Rough	<input type="checkbox"/> Loose/Loamy	<input type="checkbox"/> Dry
		<input type="checkbox"/> Wet	<input type="checkbox"/> Grass	<input type="checkbox"/> Low Bite	<input type="checkbox"/> High Bite
		<input type="checkbox"/> Dusty	<input type="checkbox"/> Astro Turf	<input type="checkbox"/> Med Bite	<input type="checkbox"/> Other _____

### FRONT SUSPENSION

Toe: \_\_\_\_\_

Ride Height: \_\_\_\_\_ Camber: \_\_\_\_\_

Caster:  0°  5°

Kick Angle:  20°  25°  30°

VLA Setting:  Short Arm  Long Arm

Oil: \_\_\_\_\_

Piston: \_\_\_\_\_

Spring:  Standard  Low Freq. Color: \_\_\_\_\_

Front Pivot:  Aluminum  Plastic  HRC

Kick Shim:  Brass  Plastic

Shock Limiters: \_\_\_\_\_ Stroke: \_\_\_\_\_

Shock Location: \_\_\_\_\_

Steering Type:  Slide Rack  Bell Cranks

Spindle Ball Stud:  Standard  Low Mount

Bumper Steer Spacers: \_\_\_\_\_

Ackermann Ball Stud:  Standard  Low Mount

Ackermann Spacers: \_\_\_\_\_

Camber Link: \_\_\_\_\_

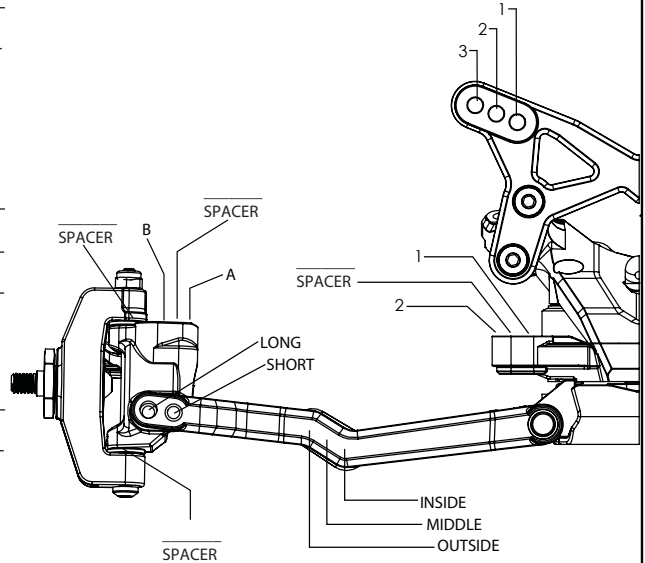

Notes:

### REAR SUSPENSION

Transmission Type:  3-Gear  4-Gear

Toe Inserts:  0.5°  1°  1.5°  2°  2.5°  3°  3.5°  4°

Anti-Squat Inserts:  0°  .5°  1°  1.5°  2°  2.5°  3°

Roll Center:  Low Roll Center (LRC)  High Roll Center (HRC)

Ride Height: \_\_\_\_\_ Camber: \_\_\_\_\_

Rear Hub Spacing: \_\_\_\_\_

Hex Width: \_\_\_\_\_

Sway Bar: \_\_\_\_\_

Oil: \_\_\_\_\_

Piston: \_\_\_\_\_

Spring:  Standard  Low Freq. Color: \_\_\_\_\_

Shock Limiters: \_\_\_\_\_ Stroke: \_\_\_\_\_

Shock Location: \_\_\_\_\_

Inner Link Spacer:  -1mm  0mm  +1mm

Camber Link: \_\_\_\_\_

Wing/Wickerbill: \_\_\_\_\_

Battery Position: \_\_\_\_\_

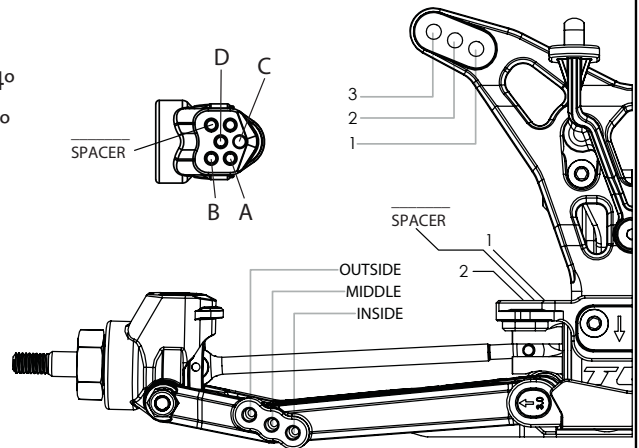

<b>ELECTRONICS</b>		Timing Advance: _____
Radio: _____	Throttle/Brake Expo: _____	
Servo: _____	Servo Expo: _____	
ESC: _____	Throttle/Brake EPA: _____	
Initial Brake: _____	Motor: _____	
Drag Brake: _____	Pinion: _____ Spur: _____	
Throttle Profile: _____	Battery: _____	

Weight Placement  
(Mark with "X")

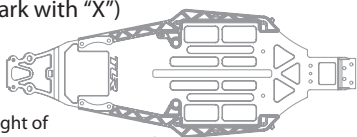

Weight of each piece \_\_\_\_\_ oz./g

### TIRES

Front: \_\_\_\_\_

Rear: \_\_\_\_\_

Notes: \_\_\_\_\_

Compound	Insert	Additive
----------	--------	----------

\_\_\_\_\_

\_\_\_\_\_

\_\_\_\_\_