

Name: _____
 City: _____ State: _____

Date: _____ Event: _____
 Track: _____

Track Conditions: Indoor Tight Smooth Hard Packed Blue Groove Wet Grass Low Bite High Bite
 Outdoor Open Rough Loose/Loamy Dry Dusty Astro Turf Med Bite Other _____

FRONT SUSPENSION

Toe: _____
 Ride Height: _____ Camber: _____
 Caster: 0° 5°
 Kick Angle: 20° 25° 30°
 VLA Setting: Short Arm Long Arm
 Oil: _____
 Piston: _____
 Spring: Standard Low Freq. Color: _____
 Front Pivot: Aluminum Plastic HRC
 Kick Shim: Brass Plastic
 Shock Limiters: _____ Stroke: _____
 Shock Location: _____
 Steering Type: Slide Rack Bell Cranks
 Spindle Ball Stud: Standard Low Mount
 Bumper Steer Spacers: _____
 Ackermann Ball Stud: Standard Low Mount
 Ackermann Spacers: _____
 Camber Link: _____

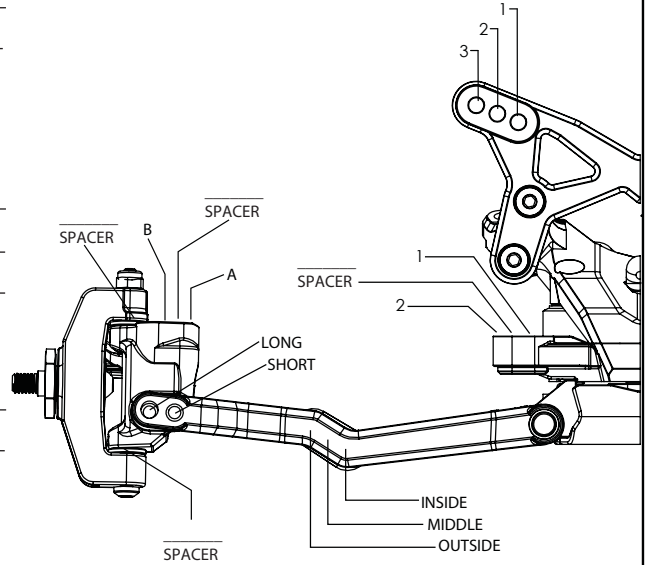

Notes: _____

REAR SUSPENSION

Transmission Type: 3-Gear 4-Gear
 Toe Inserts: 0.5° 1° 1.5° 2° 2.5° 3° 3.5° 4°
 Anti-Squat Inserts: 0° .5° 1° 1.5° 2° 2.5° 3°
 Roll Center: Low Roll Center (LRC) High Roll Center (HRC)
 Ride Height: _____ Camber: _____
 Rear Hub Spacing: _____
 Hex Width: _____
 Sway Bar: _____
 Oil: _____
 Piston: _____
 Spring: Standard Low Freq. Color: _____
 Shock Limiters: _____ Stroke: _____
 Shock Location: _____
 Inner Link Spacer: -1mm 0mm +1mm
 Camber Link: _____
 Wing/Wickerbill: _____
 Battery Position: _____

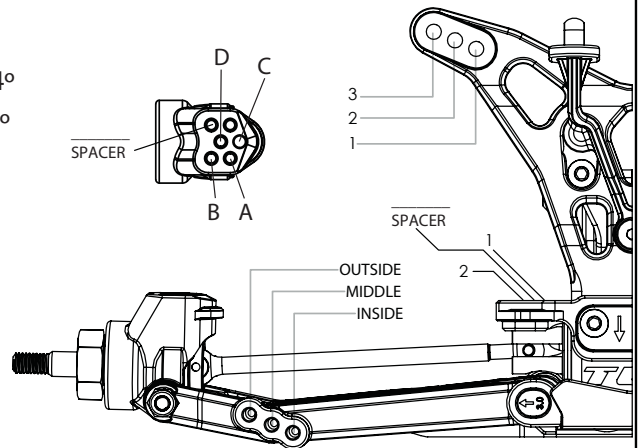

ELECTRONICS Timing Advance: _____
 Radio: _____ Throttle/Brake Expo: _____
 Servo: _____ Servo Expo: _____
 ESC: _____ Throttle/Brake EPA: _____
 Initial Brake: _____ Motor: _____
 Drag Brake: _____ Pinion: _____ Spur: _____
 Throttle Profile: _____ Battery: _____

Weight Placement
 (Mark with "X")

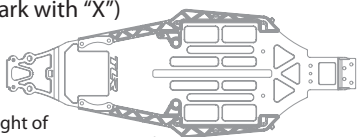

Weight of each piece _____ oz./g

TIRES

Compound Insert Additive
 Front: _____
 Rear: _____
 Notes: _____