

Name: _____		Date: _____	Event: _____
City: _____		Track: _____	
Track Conditions	<input type="checkbox"/> Indoor <input type="checkbox"/> Tight <input type="checkbox"/> Smooth <input type="checkbox"/> Hard Packed <input type="checkbox"/> Blue Groove	<input type="checkbox"/> Wet <input type="checkbox"/> Grass <input type="checkbox"/> Low Bite <input type="checkbox"/> High Bite	
	<input type="checkbox"/> Outdoor <input type="checkbox"/> Open <input type="checkbox"/> Rough <input type="checkbox"/> Loose/Loamy <input type="checkbox"/> Dry	<input type="checkbox"/> Dusty <input type="checkbox"/> Astro Turf <input type="checkbox"/> Med Bite <input type="checkbox"/> Other _____	

Front Suspension

Toe: _____

Ride Height: _____

Camber: _____

Caster: 0° 5° Trail: 2mm 4mm

Kick Angle: 20° 25° 30°

Sway Bar: _____

Oil: _____

Piston: _____

Spring: Standard Low Freq. Color: _____

Front Pivot: Aluminum Plastic HRC

Kick Shim: Brass Plastic

Shock Limiters: _____

Shock Location: _____

Bump Steer Ball Stud: Standard Low Mount

Bumper Steer Spacers: _____

Ackermann Ball Stud: Standard Low Mount

Ackermann Spacers: _____

Camber Link: _____

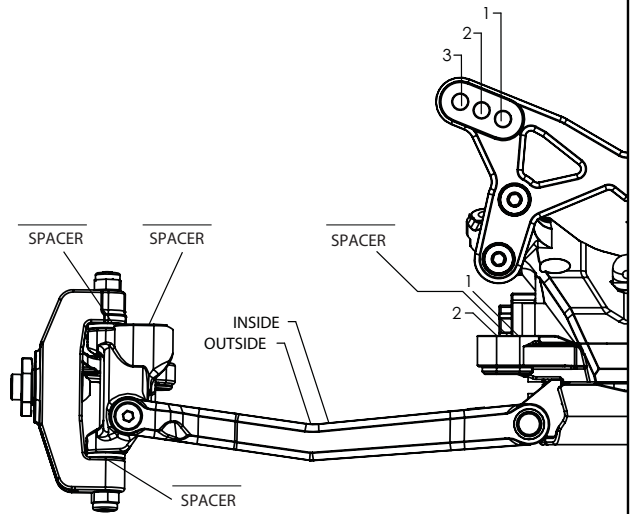

Notes:

Rear Suspension

Chassis Configuration: Rear Motor Mid Motor

Toe: _____

Anti-Squat: _____

Roll Center: Low Roll Center (LRC) High Roll Center (HRC)

Ride Height: _____

Camber: _____

Rear Hub Spacing: _____

Hex Width: _____

Sway Bar: _____

Oil: _____

Piston: _____

Spring: Standard Low Freq. Color: _____

Shock Limiters: _____

Camber Link: _____

Shock Locations: _____

Wing/Wickerbill: _____

Battery Position: _____

Ball Diff:

Gear Diff:

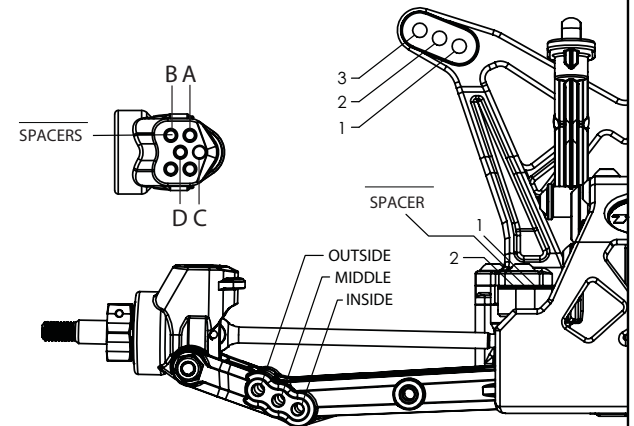

Electronics Team Orion R10 Setup

Radio: _____	Running Mode: _____
Servo: _____	Drag Brake: _____
Motor: _____	Voltage Protection: _____
Pinion: _____ Spur: _____	DRRS Punch: _____
Battery: _____	Brake Force: _____
Timing Advance: _____	Reverse Force: _____
Th/Brake EPA: _____	Initial Brake: _____
Th/Brake Expo: _____	Neutral Range: _____
Servo Expo: _____	Overheat Protection: _____
	Boost Timing: _____
	Turbo Timing: _____
	Turbo Slope: _____
	Turbo Delay: _____

<p>Weight Placement (Mark with "X")</p> <p>Weight of each piece _____ oz./g</p>	Front	Rear
	Tire: _____	_____
	Insert: _____	_____
	Wheel: _____	_____
	Notes: _____	_____

Comments: _____