

Name: _____		Date: _____	Event: _____
City: _____		State: _____	
Track: _____			
Track Conditions	<input type="checkbox"/> Indoor <input type="checkbox"/> Tight <input type="checkbox"/> Smooth <input type="checkbox"/> Hard Packed <input type="checkbox"/> Blue Groove	<input type="checkbox"/> Wet <input type="checkbox"/> Grass <input type="checkbox"/> Low Bite <input type="checkbox"/> High Bite	
	<input type="checkbox"/> Outdoor <input type="checkbox"/> Open <input type="checkbox"/> Rough <input type="checkbox"/> Loose/Loamy <input type="checkbox"/> Dry	<input type="checkbox"/> Dusty <input type="checkbox"/> Astro Turf <input type="checkbox"/> Med Bite <input type="checkbox"/> Other _____	

**Front Suspension**

Toe: \_\_\_\_\_

Ride Height: \_\_\_\_\_

Camber: \_\_\_\_\_

Caster:  0°  5°      Trail:  2mm  4mm

Kick Angle:  20°  25°  30°

Sway Bar: \_\_\_\_\_

Oil: \_\_\_\_\_

Piston: \_\_\_\_\_

Spring:  Standard  Low Freq.      Color: \_\_\_\_\_

Front Pivot:  Aluminum  Plastic  HRC

Kick Shim:  Brass  Plastic

Shock Limiters: \_\_\_\_\_

Shock Location: \_\_\_\_\_

Bump Steer Ball Stud:  Standard  Low Mount

Bumper Steer Spacers: \_\_\_\_\_

Ackermann Ball Stud:  Standard  Low Mount

Ackermann Spacers: \_\_\_\_\_

Camber Link: \_\_\_\_\_

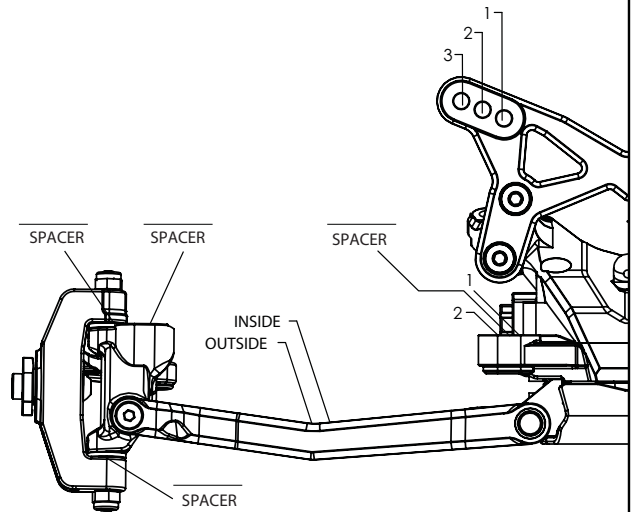

Notes: \_\_\_\_\_

\_\_\_\_\_

\_\_\_\_\_

**Rear Suspension**

Chassis Configuration:  Rear Motor  Mid Motor

Toe: \_\_\_\_\_

Anti-Squat: \_\_\_\_\_

Roll Center:  Low Roll Center (LRC)  High Roll Center (HRC)

Ride Height: \_\_\_\_\_

Camber: \_\_\_\_\_

Rear Hub Spacing: \_\_\_\_\_

Hex Width: \_\_\_\_\_

Sway Bar: \_\_\_\_\_

Oil: \_\_\_\_\_

Piston: \_\_\_\_\_

Spring:  Standard  Low Freq.      Color: \_\_\_\_\_

Shock Limiters: \_\_\_\_\_

Camber Link: \_\_\_\_\_

Shock Locations: \_\_\_\_\_

Wing/Wickerbill: \_\_\_\_\_

Battery Position: \_\_\_\_\_

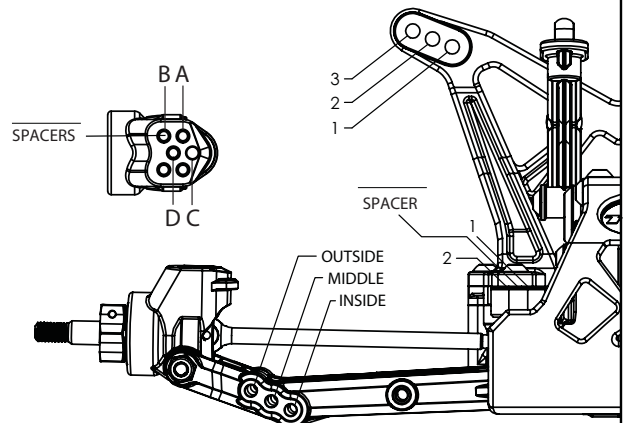

**Electronics**

Radio: _____	Timing Advance: _____
Servo: _____	Throttle/Brake Expo: _____
ESC: _____	Servo Expo: _____
Initial Brake: _____	Throttle/Brake EPA: _____
Drag Brake: _____	Motor: _____
Throttle Profile: _____	Pinion: _____ Spur: _____
	Battery: _____

Weight Placement (Mark with "X")

Weight of each piece \_\_\_\_\_ oz./g

Tires

Front: \_\_\_\_\_

Rear: \_\_\_\_\_

Notes: \_\_\_\_\_

Compound	Insert	Additive
_____	_____	_____
_____	_____	_____