

Name: David Poulter Date: 15/12/2013 Event: Winter Series Rnd 3
 City: Stitfold State: _____ Track: Stotfold MCC

Track Conditions: Indoor Tight Smooth Hard Packed Blue Groove Wet Grass Low Bite High Bite
 Outdoor Open Rough Loose/Loamy Dry Dusty Astro Turf Med Bite Other _____

Front Suspension

Toe: 0°
 Ride Height: 19mm
 Camber: -1°
 Caster: 0° 5° Trail: 2mm 4mm
 Kick Angle: 20° 25° 30°
 Sway Bar: _____
 Oil: 500
 Piston: 4 Hole - 55
 Spring: Standard Low Freq. Color: Silver
 Front Pivot: Aluminum Plastic HRC
 Kick Shim: Brass Plastic
 Shock Limiters: 1 x 1mm & 2 x 2mm
 Shock Location: 2I
 Bump Steer Ball Stud: Standard Low Mount
 Bumper Steer Spacers: 1.0
 Ackermann Ball Stud: Standard Low Mount
 Ackermann Spacers: 0.0
 Camber Link: 2 Inner

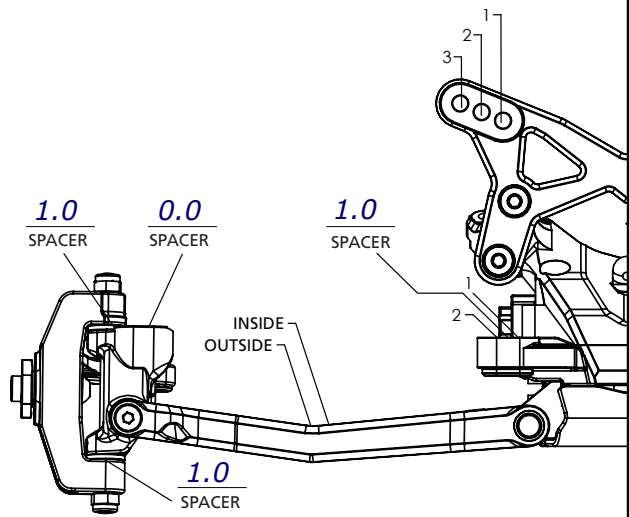

Notes: _____
Ball Diff

Rear Suspension

Chassis Configuration: Rear Motor Mid Motor
 Toe: 4°
 Anti-Squat: 2°
 Roll Center: Low Roll Center (LRC) High Roll Center (HRC)
 Ride Height: 20mm
 Camber: -1.0
 Rear Hub Spacing: Front - 4mm Rear
 Hex Width: Standard
 Sway Bar: _____
 Oil: 250
 Piston: 4 Hole - 55
 Spring: Standard Low Freq. Color: Yellow
 Shock Limiters: None
 Camber Link: 1 F (Outer Rear) Outer Spacer = 1mm
 Shock Locations: 2 Inside
 Wing/Wickerbill: LMR
 Battery Position: Rear - Shorty

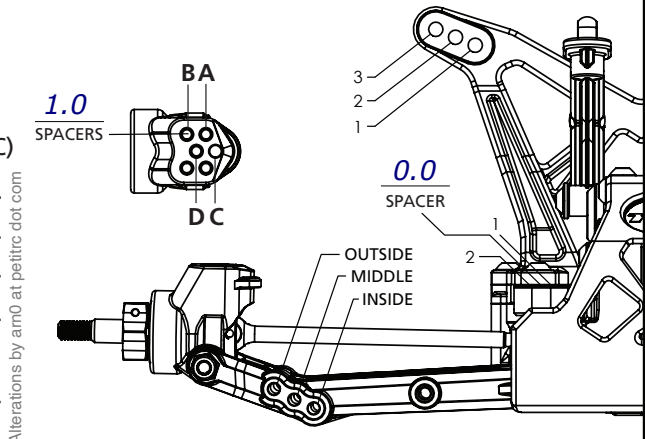

Electronics

Radio: Sanwa Timing Advance: _____
 Servo: Orion Throttle/Brake Expo: _____
 ESC: Orion R10 Servo Expo: _____
 Initial Brake: _____ Throttle/Brake EPA: _____
 Drag Brake: _____ Motor: Orion VST2 7.5
 Throttle Profile: _____ Pinion: 23T Spur: Kit 78T
 Battery: Orion Shorty

Weight Placement (Mark with "X")

Tires Front: Sch Stagger Rib. Compound: Silver. Insert: None Additive: _____
 Rear: Sch MiniSpike. Compound: Silver. Insert: Mr O Foams Additive: _____
 Notes: Qualified 6th and finished 3rd

Weight of each piece _____ oz./g

