

Name: David Poulter Date: 09/11/2013 Event: Winter Series Rnd 2  
 City: Moulton College State: \_\_\_\_\_ Track: Silverstone

Track Conditions:  Indoor  Tight  Smooth  Hard Packed  Blue Groove  Wet  Grass  Low Bite  High Bite  
 Outdoor  Open  Rough  Loose/Loamy  Dry  Dusty  Astro Turf  Med Bite  Other \_\_\_\_\_

**Front Suspension**

Toe: 0°  
 Ride Height: 18mm  
 Camber: -1°  
 Caster:  0°  5° Trail:  2mm  4mm  
 Kick Angle:  20°  25°  30°  
 Sway Bar: \_\_\_\_\_  
 Oil: 500  
 Piston: 4 Hole 55  
 Spring:  Standard  Low Freq. Color: Green  
 Front Pivot:  Aluminum  Plastic  HRC  
 Kick Shim:  Brass  Plastic  
 Shock Limiters: 1 x 1mm & 1 x 2mm  
 Shock Location: 2I  
 Bump Steer Ball Stud:  Standard  Low Mount  
 Bumper Steer Spacers: 1.0  
 Ackermann Ball Stud:  Standard  Low Mount  
 Ackermann Spacers: 0.0  
 Camber Link: 2 Inner

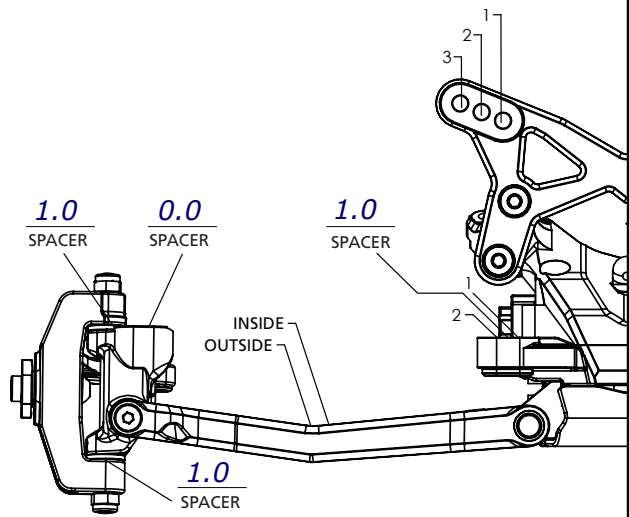

Notes: \_\_\_\_\_  
Geared Diff with 3K

**Rear Suspension**

Chassis Configuration:  Rear Motor  Mid Motor  
 Toe: 3°  
 Anti-Squat: 2°  
 Roll Center:  Low Roll Center (LRC)  High Roll Center (HRC)  
 Ride Height: 19mm  
 Camber: -1  
 Rear Hub Spacing: Long - 4mm in front  
 Hex Width: Standard  
 Sway Bar: \_\_\_\_\_  
 Oil: 350  
 Piston: 4 Hole 55  
 Spring:  Standard  Low Freq. Color: Pink  
 Shock Limiters: None  
 Camber Link: 1 A Rear Position - Straight Link  
 Shock Locations: 2 Middle  
 Wing/Wickerbill: LMR  
 Battery Position: Rear - Shorty

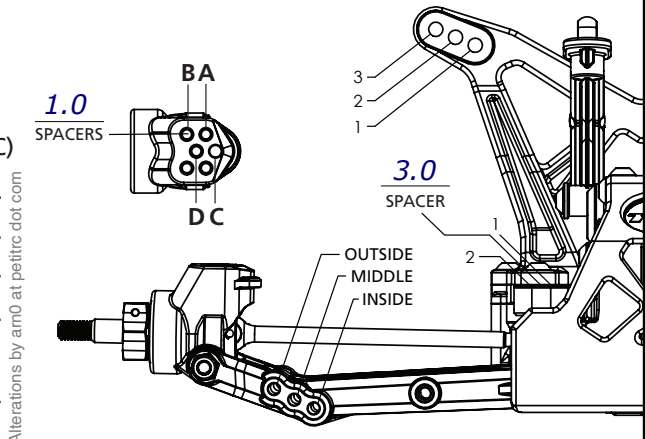

**Electronics**

Radio: Sanwa Timing Advance: \_\_\_\_\_  
 Servo: Orion Throttle/Brake Expo: \_\_\_\_\_  
 ESC: Orion R10 Servo Expo: \_\_\_\_\_  
 Initial Brake: \_\_\_\_\_ Throttle/Brake EPA: \_\_\_\_\_  
 Drag Brake: \_\_\_\_\_ Motor: Orion VST2 7.5  
 Throttle Profile: \_\_\_\_\_ Pinion: 22T Spur: Kit 78T  
 Battery: Orion Shorty

Weight Placement (Mark with "X")

Tires Front: Sch Stagger Rib. Compound Yellow. Insert None Additive \_\_\_\_\_  
 Rear: Sch MiniSpike. Yellow. Mr O Foams \_\_\_\_\_  
 Notes: Qualified 11th with 13,11,9 & 6 Round Scores. Won the B Final and finished 11th overall

Weight of each piece \_\_\_\_\_ oz./g

