

Name: \_\_\_\_\_ Date: \_\_\_\_\_ Event: \_\_\_\_\_  
 City: \_\_\_\_\_ State: \_\_\_\_\_ Track: \_\_\_\_\_

Track Conditions:  Indoor  Tight  Smooth  Hard Packed  Blue Groove  Wet  Grass  Low Bite  High Bite  
 Outdoor  Open  Rough  Loose/Loamy  Dry  Dusty  Astro Turf  Med Bite  Other \_\_\_\_\_

**Front Suspension**

Toe: \_\_\_\_\_  
 Ride Height: \_\_\_\_\_  
 Camber: \_\_\_\_\_  
 Caster:  0°  5° Trail:  2mm  4mm  
 Kick Angle:  20°  25°  30°  
 Sway Bar: \_\_\_\_\_  
 Oil: \_\_\_\_\_  
 Piston: \_\_\_\_\_  
 Spring:  Standard  Low Freq. Color: \_\_\_\_\_  
 Front Pivot:  Aluminum  Plastic  HRC  
 Kick Shim:  Brass  Plastic  
 Shock Limiters: \_\_\_\_\_  
 Shock Location: \_\_\_\_\_  
 Bump Steer Ball Stud:  Standard  Low Mount  
 Bumper Steer Spacers: \_\_\_\_\_  
 Ackermann Ball Stud:  Standard  Low Mount  
 Ackermann Spacers: \_\_\_\_\_  
 Camber Link: \_\_\_\_\_

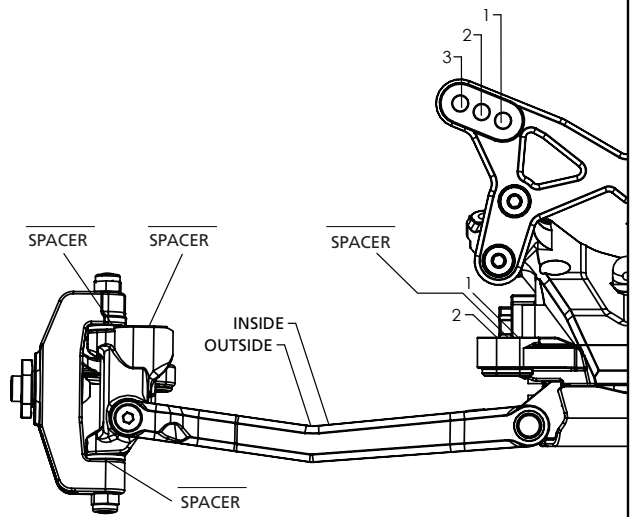

Notes: \_\_\_\_\_  
 \_\_\_\_\_  
 \_\_\_\_\_

**Rear Suspension**

Chassis Configuration:  Rear Motor  Mid Motor  
 Toe: \_\_\_\_\_  
 Anti-Squat: \_\_\_\_\_  
 Roll Center:  Low Roll Center (LRC)  High Roll Center (HRC)  
 Ride Height: \_\_\_\_\_  
 Camber: \_\_\_\_\_  
 Rear Hub Spacing: \_\_\_\_\_  
 Hex Width: \_\_\_\_\_  
 Sway Bar: \_\_\_\_\_  
 Oil: \_\_\_\_\_  
 Piston: \_\_\_\_\_  
 Spring:  Standard  Low Freq. Color: \_\_\_\_\_  
 Shock Limiters: \_\_\_\_\_  
 Camber Link: \_\_\_\_\_  
 Shock Locations: \_\_\_\_\_  
 Wing/Wickerbill: \_\_\_\_\_  
 Battery Position: \_\_\_\_\_

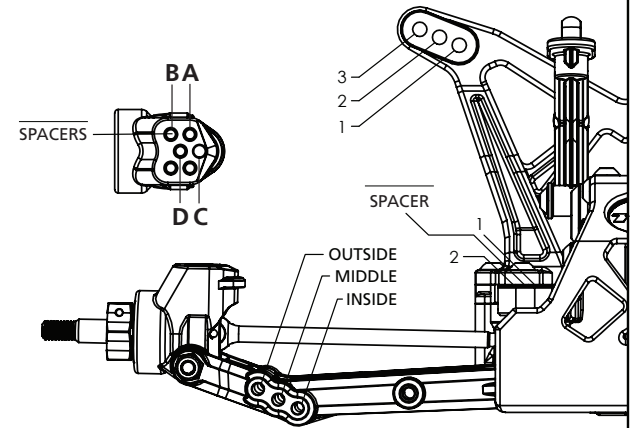

**Electronics**

Radio: \_\_\_\_\_ Timing Advance: \_\_\_\_\_  
 Servo: \_\_\_\_\_ Throttle/Brake Expo: \_\_\_\_\_  
 ESC: \_\_\_\_\_ Servo Expo: \_\_\_\_\_  
 Initial Brake: \_\_\_\_\_ Throttle/Brake EPA: \_\_\_\_\_  
 Drag Brake: \_\_\_\_\_ Motor: \_\_\_\_\_  
 Throttle Profile: \_\_\_\_\_ Pinion: \_\_\_\_\_ Spur: \_\_\_\_\_  
 Battery: \_\_\_\_\_

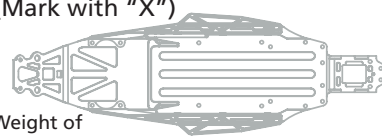
Weight Placement (Mark with "X")  
  
 Weight of each piece \_\_\_\_\_ oz./g  
 Tires Front: \_\_\_\_\_ Compound \_\_\_\_\_ Insert \_\_\_\_\_ Additive \_\_\_\_\_  
 Rear: \_\_\_\_\_  
 Notes: \_\_\_\_\_