

Name: _____	Date: _____
City: _____	Event: _____
State: _____	Track: _____
Track Conditions: <input type="checkbox"/> Indoor <input type="checkbox"/> Tight <input type="checkbox"/> Smooth <input type="checkbox"/> Hard Packed <input type="checkbox"/> Blue Groove <input type="checkbox"/> Wet <input type="checkbox"/> Grass <input type="checkbox"/> Low Bite <input type="checkbox"/> High Bite <input type="checkbox"/> Outdoor <input type="checkbox"/> Open <input type="checkbox"/> Rough <input type="checkbox"/> Loose/Loamy <input type="checkbox"/> Dry <input type="checkbox"/> Dusty <input type="checkbox"/> Astro Turf <input type="checkbox"/> Med Bite <input type="checkbox"/> Other _____	

Front Suspension

Toe: _____
 Ride Height: _____
 Camber: _____
 Caster: 0° 3° 5° 10°
 Kick Angle: 20° 25° 30°
 Sway Bar: _____
 Oil: _____
 Piston: _____
 Spring: _____
 Spindle Type: Inline Trailing
 Shock Limiters: _____
 Shock Location: _____
 Bump Steer: _____
 Camber Link: _____

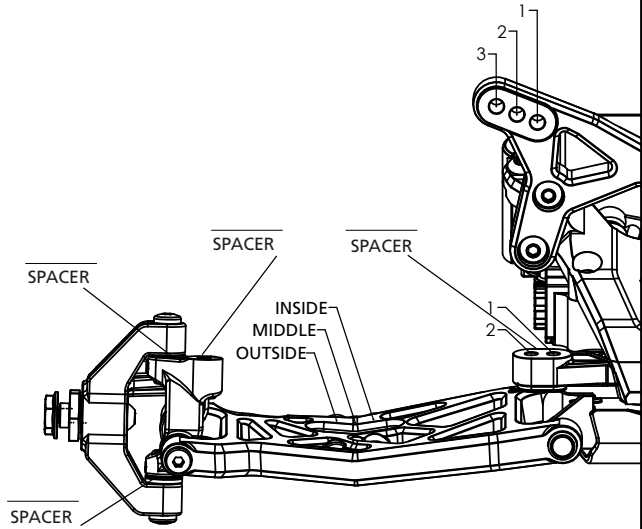

Notes: _____

Rear Suspension

Chassis Configuration: Rear Motor Mid Motor
 Toe: _____
 Anti-Squat: _____
 Roll Center: Low Roll Center (LRC) High Roll Center (HRC)
 Ride Height: _____
 Camber: _____
 Rear Hub Spacing: _____
 Hex Width: _____
 Sway Bar: _____
 Oil: _____
 Piston: _____
 Spring: _____
 Shock Limiters: _____
 Camber Link: _____
 Shock Locations: _____
 Wing/Wickerbill: _____
 Battery Position: _____

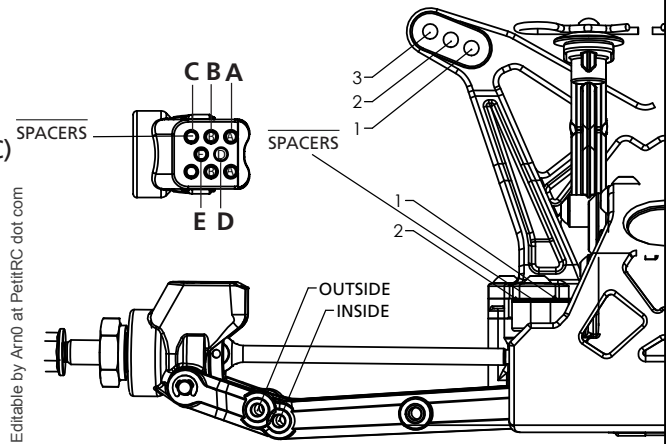

Electronics

Radio: _____
 Servo: _____
 ESC: _____
 Initial Brake: _____
 Drag Brake: _____
 Throttle Profile: _____
 Timing Advance: _____
 Throttle/Brake Expo: _____
 Servo Expo: _____
 Throttle/Brake EPA: _____
 Motor: _____
 Pinion: _____ Spur: _____
 Battery: _____

Weight Placement (Mark with "X")  Weight of each piece _____ oz./g	Tires Front: _____ Rear: _____ Notes: _____	Compound _____ _____	Insert _____ _____	Additive _____ _____
--	--	----------------------------	--------------------------	----------------------------