

Name: Kenji Tsuruta Date: 7/14/2013 Event: TRESREY OFF-ROAD RACE R

City: 奈良県 State: 五條市 Track: RC PARK GOJO

Track  Indoor  Tight  Smooth  Hard Packed  Blue Groove  Wet  Grass  Low Bite  High Bite  
 Conditions  Outdoor  Open  Rough  Loose/Loamy  Dry  Dusty  Astro Turf  Med Bite  Other \_\_\_\_\_

**Front Suspension**

Toe: 0 Degree  
 Ride Height: 24mm  
 Camber: -1 Degree  
 Caster:  0°  3°  5°  10°  
 Kick Angle:  20°  25°  30°  
 Sway Bar: NO  
 Oil: 30wt  
 Piston: 1.6mmx2  
 Spring: LF Red  
 Spindle Type:  Inline  Trailing  
 Shock Limiters: 3.5mm  
 Shock Location: #2 on Tower, Middle on Arm  
 Bump Steer: 1mm  
 Camber Link: 2

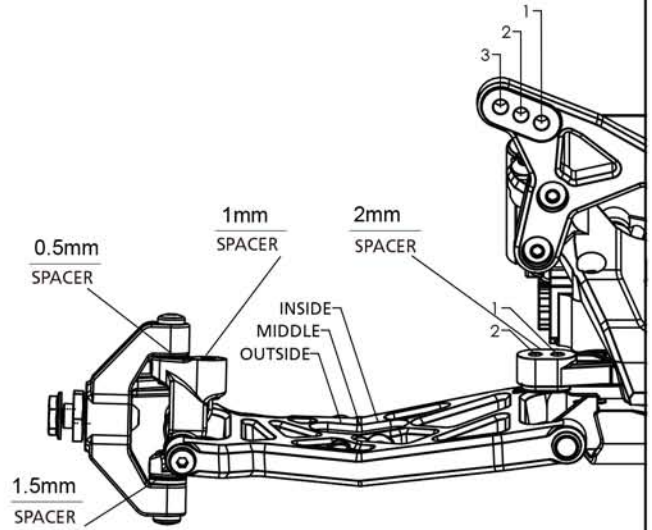

Notes: \_\_\_\_\_  
 TLR2059 アルミフロントキャンパーブロック  
 TLR1049 プラスキックアングルシム (22用/25度)

**Rear Suspension**

Chassis Configuration:  Rear Motor  Mid Motor  
 Toe: 3.5 Degree  
 Anti-Squat: 2.5 Degree  
 Roll Center:  Low Roll Center (LRC)  High Roll Center (HRC)  
 Ride Height: 24mm  
 Camber: -1.5 Degree  
 Rear Hub Spacing: Middle  
 Hex Width: +.75mm(TLR2931)  
 Sway Bar: NO  
 Oil: 27.5wt  
 Piston: 1.6mmx2  
 Spring: LF Yellow  
 Shock Limiters: 0.5mm  
 Camber Link: 2/B  
 Shock Locations: #2 on tower, inside on Arm  
 Wing/Wickerbill: Forward  
 Battery Position: Forward

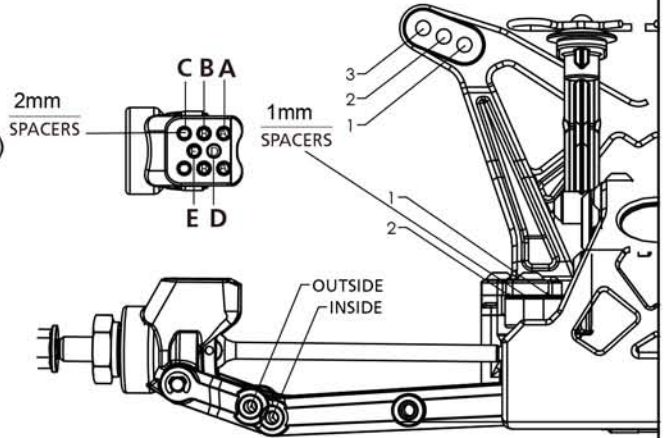

**Electronics**

Radio: FUTABA 4PKS  
 Servo: BLS451  
 ESC: SP Reventon-PRO  
 Initial Brake: \_\_\_\_\_  
 Drag Brake: \_\_\_\_\_  
 Throttle Profile: \_\_\_\_\_  
 Timing Advance: \_\_\_\_\_  
 Throttle/Brake Expo: \_\_\_\_\_  
 Servo Expo: \_\_\_\_\_  
 Throttle/Brake EPA: \_\_\_\_\_  
 Motor: SP V3.0 7.5T  
 Pinion: 20 Spur: 78  
 Battery: \_\_\_\_\_

Weight Placement (Mark with "X")	Tires	Compound	Insert	Additive
 Weight of each piece <u>20</u> oz./g	Front: <u>Panther</u>	<u>Cray</u>	<u>Closed Cell</u>	_____
	Rear: <u>Panther</u>	<u>Cray</u>	<u>Closed Cell</u>	_____
Notes: <u>TLR2060アルミリアキャンパーブロック、TLR334000ブリーダーショックキャップOリング</u> <u>TLR5065アルミブリーダーショックキャップ、TLR5074ローフリクションショックシャフトO!</u>				