

Name: _____ Date: _____ Event: _____

City: _____ State: _____ Track: _____

Track Conditions: Indoor Tight Smooth Hard Packed Blue Groove Wet Grass Low Bite High Bite
 Outdoor Open Rough Loose/Loamy Dry Dusty Astro Turf Med Bite Other _____

Front Suspension

Toe: _____
 Ride Height: _____
 Camber: _____
 Caster: 0° 3° 5° 10°
 Kick Angle: 20° 25° 30°
 Sway Bar: _____
 Oil: _____
 Piston: _____
 Spring: _____
 Spindle Type: Inline Trailing
 Shock Limiters: _____
 Shock Location: _____
 Bump Steer: _____
 Camber Link: _____

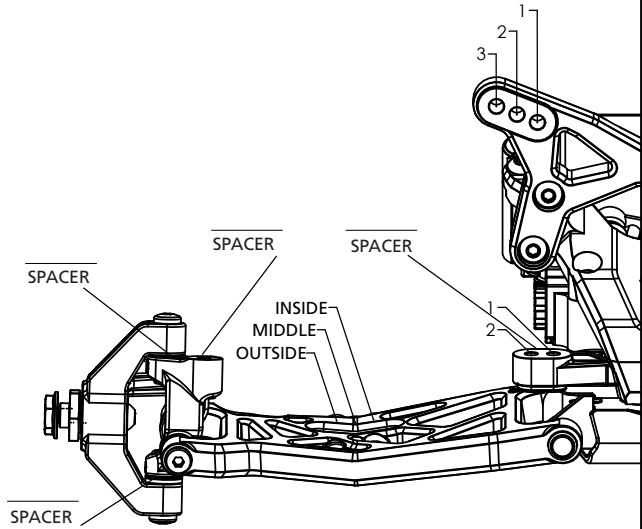

Notes: _____

Rear Suspension

Chassis Configuration: Rear Motor Mid Motor
 Toe: _____
 Anti-Squat: _____
 Roll Center: Low Roll Center (LRC) High Roll Center (HRC)
 Ride Height: _____
 Camber: _____
 Rear Hub Spacing: _____
 Hex Width: _____
 Sway Bar: _____
 Oil: _____
 Piston: _____
 Spring: _____
 Shock Limiters: _____
 Camber Link: _____
 Shock Locations: _____
 Wing/Wickerbill: _____
 Battery Position: _____

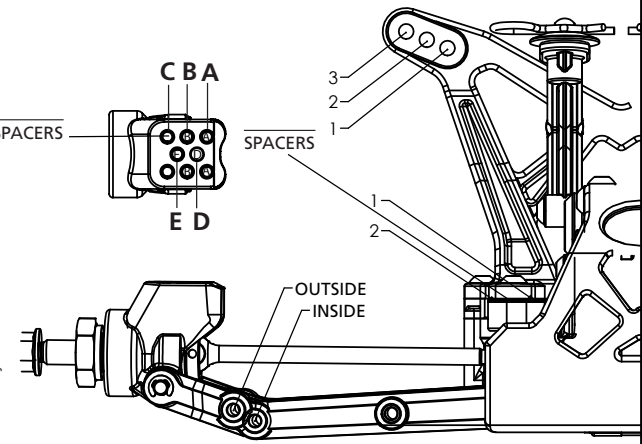

Editable by Arn0 at PettitRC dot com

Electronics

Radio: _____ Timing Advance: _____
 Servo: _____ Throttle/Brake Expo: _____
 ESC: _____ Servo Expo: _____
 Initial Brake: _____ Throttle/Brake EPA: _____
 Drag Brake: _____ Motor: _____
 Throttle Profile: _____ Pinion: _____ Spur: _____
 Battery: _____

Weight Placement (Mark with "X")	Tires	Compound	Insert	Additive
Front: _____	_____	_____	_____	_____
Rear: _____	_____	_____	_____	_____
Notes: _____	_____	_____	_____	_____

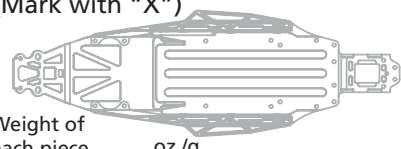

Weight of each piece _____ oz./g