

Name: \_\_\_\_\_ Date: \_\_\_\_\_ Event: \_\_\_\_\_  
 City: \_\_\_\_\_ State: \_\_\_\_\_ Track: \_\_\_\_\_

Track  Indoor  Tight  Smooth  Hard Packed  Blue Groove  Wet  Grass  Low Bite  High Bite  
 Conditions  Outdoor  Open  Rough  Loose/Loamy  Dry  Dusty  Astro Turf  Med Bite  Other \_\_\_\_\_

**Front Suspension**

Toe: \_\_\_\_\_  
 Ride Height: \_\_\_\_\_  
 Camber: \_\_\_\_\_  
 Caster:  0°  3°  5°  10°  
 Kick Angle:  20°  25°  30°  
 Sway Bar: \_\_\_\_\_  
 Oil: \_\_\_\_\_  
 Piston: \_\_\_\_\_  
 Spring: \_\_\_\_\_  
 Spindle Type:  Inline  Trailing  
 Shock Limiters: \_\_\_\_\_  
 Shock Location: \_\_\_\_\_  
 Bump Steer: \_\_\_\_\_  
 Camber Link: \_\_\_\_\_  
 \_\_\_\_\_  
 \_\_\_\_\_

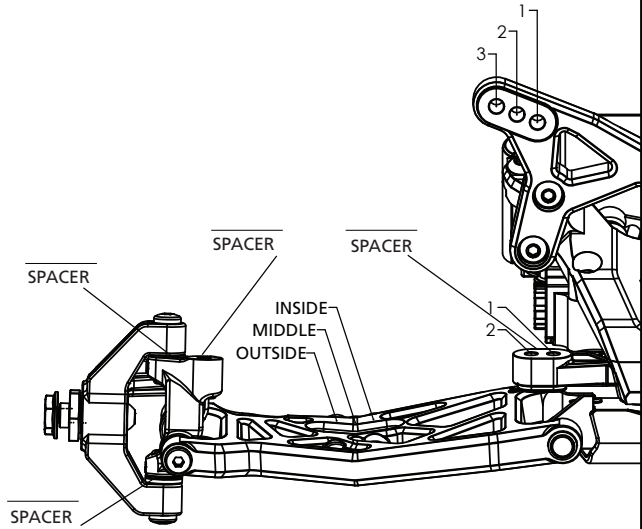

Notes: \_\_\_\_\_  
 \_\_\_\_\_  
 \_\_\_\_\_

**Rear Suspension**

Chassis Configuration:  Rear Motor  Mid Motor  
 Toe: \_\_\_\_\_  
 Anti-Squat: \_\_\_\_\_  
 Roll Center:  Low Roll Center (LRC)  High Roll Center (HRC)  
 Ride Height: \_\_\_\_\_  
 Camber: \_\_\_\_\_  
 Rear Hub Spacing: \_\_\_\_\_  
 Hex Width: \_\_\_\_\_  
 Sway Bar: \_\_\_\_\_  
 Oil: \_\_\_\_\_  
 Piston: \_\_\_\_\_  
 Spring: \_\_\_\_\_  
 Shock Limiters: \_\_\_\_\_  
 Camber Link: \_\_\_\_\_  
 Shock Locations: \_\_\_\_\_  
 Wing/Wickerbill: \_\_\_\_\_  
 Battery Position: \_\_\_\_\_

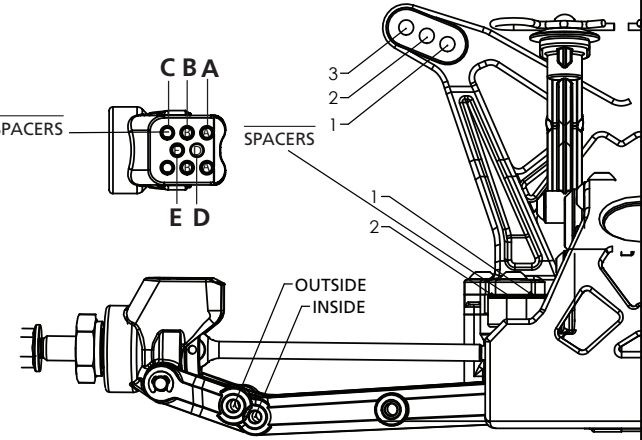

**Electronics**

Radio: \_\_\_\_\_ Timing Advance: \_\_\_\_\_  
 Servo: \_\_\_\_\_ Throttle/Brake Expo: \_\_\_\_\_  
 ESC: \_\_\_\_\_ Servo Expo: \_\_\_\_\_  
 Initial Brake: \_\_\_\_\_ Throttle/Brake EPA: \_\_\_\_\_  
 Drag Brake: \_\_\_\_\_ Motor: \_\_\_\_\_  
 Throttle Profile: \_\_\_\_\_ Pinion: \_\_\_\_\_ Spur: \_\_\_\_\_  
 Battery: \_\_\_\_\_

Weight Placement (Mark with "X")	Tires	Compound	Insert	Additive
Front: _____	Front: _____	_____	_____	_____
Rear: _____	Rear: _____	_____	_____	_____
Notes: _____	Notes: _____	_____	_____	_____

Weight of each piece \_\_\_\_\_ oz./g

