

Name: _____	Date: _____ Event: _____
City: _____ State: _____	Track: _____

Track Indoor Tight Smooth Hard Packed Blue Groove Wet Low Bite High Bite
 Conditions Outdoor Open Rough Loose/Loamy Dry Dusty Med Bite Other _____

Front Suspension

Toe: 1/2°
 Ride Height: 1.22 in
 Camber: -1/2°
 Caster: Stock
 Sway Bar: No
 Oil: 30 wt.
 Piston: 57
 Spring: Silver
 Limiters: .210 in
 Spindle Height: Bottom
 Axle Spacer: Inside
 Axle Spacer Size: .100 in
 Steering Type: Bellcrank
 Bump Steer: 3 ball stud washers
 Camber Link: 2-B 2 washers under inner
 Shock Location: Inside
 VLA: Short

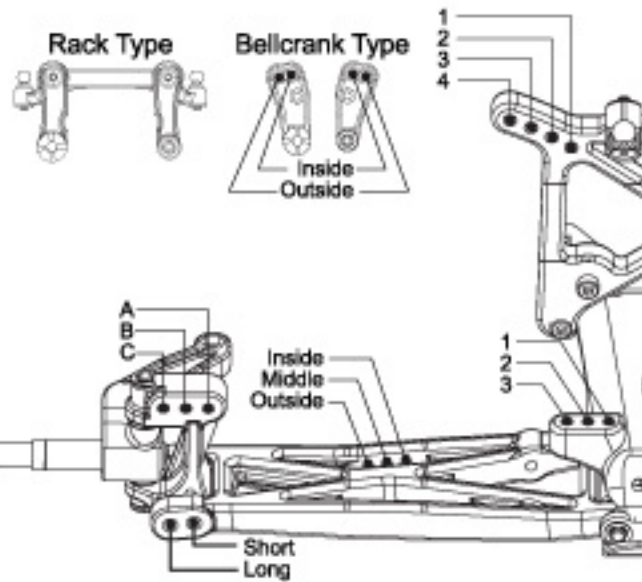

Notes: _____

Rear Suspension

Toe: 3°
 Pivot Support: _____
 Ride Height: 1.18 in
 Camber: -1°
 Rear Hub Spacing: Center
 Drive Shafts/Outdrives: CV/Steel
 Sway Bar: No
 Oil: 30 wt.
 Piston: 55
 Spring: White
 Limiters: No
 Camber Link: 2/B with 3 washers
 Shock Location: Middle
 VLA: Short
 Wing Width & Height: Stock
 Body Type: Stock
 Battery Position: Middle

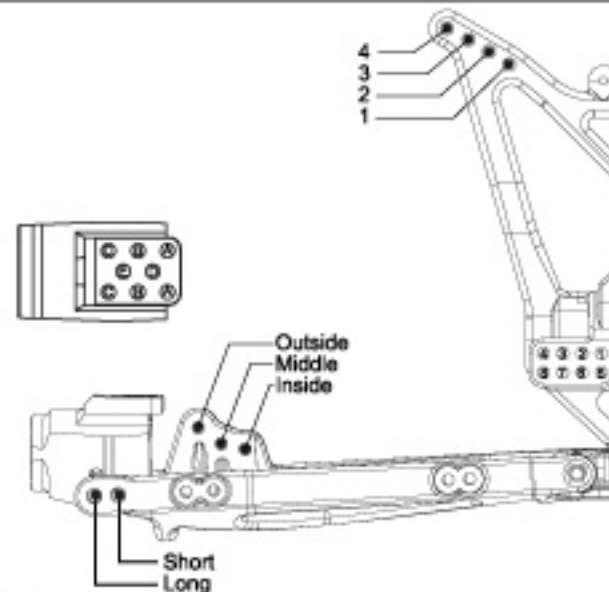

Notes: _____

Weight Placement
(Mark with "X")

Weight of each piece _____ oz.

Tires:	Type	Compound	Insert	Additive	Motor: _____
Front:	8-Rib	Red	_____	_____	Spur: _____
Rear:	King Pin	Red	_____	_____	Pinon: _____
Notes:	_____				