

Setup Sheet

Track: Standard Set Up

Driver: Adam Drake

Indoor
 Outdoor

Smooth
 Rough

Slippery
 High-Bite
 Blue-Groove

Date: January 2001

Tight / Open

FRONT SUSPENSION *(Circle or Check the Appropriate Settings)*

Toe In 1 °
 Out

Ride Height Arms Level

Camber - 1 °
 +

Caster Stock
 Other

Sway Bar No
 Yes size

of washers under steering / tie-rod ball studs
Spindle ball stud: 1
Bellcrank ball stud: 0

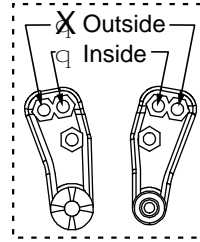

of washers under ball stud: 1

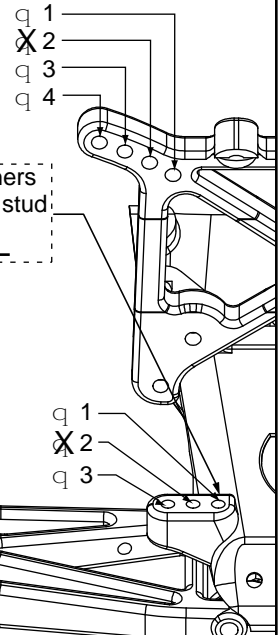

Front Shocks

Oil: 30 wt Losi
Piston: 56 Standard / Drilled
Spring: Orange
Limiters: Inside- .120 Outside- none

Spindle Location

Top
 Middle
 Bottom

REAR SUSPENSION

Toe-In Inside 3 °
 Outside

Pivot Support 2 deg No Shim
 Shim Under Front Shim Under Rear > # of shims: _____

Ride Height Bones Level

Camber - 1/2 °
 +

Drive Shafts Dogbones Aluminum
 CVDs Steel

Rear Hub Spacing Forward
 Center
 Rear

Outdrives Steel
 Plastic

Sway Bar No
 Yes size

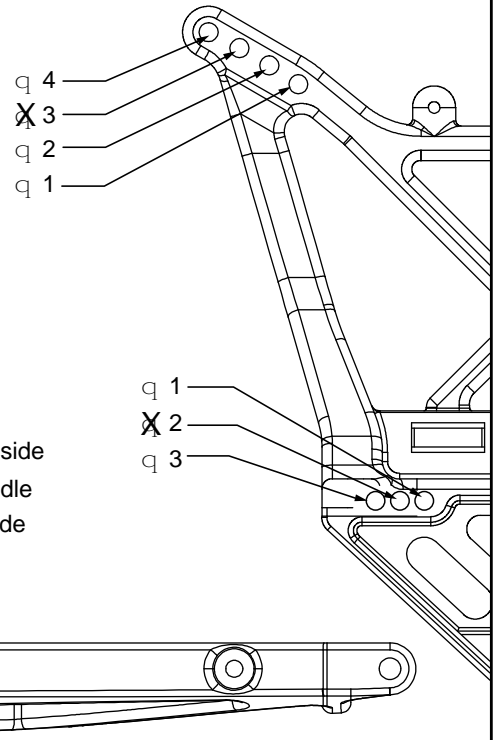

Rear Shocks

Oil: 30 wt Losi
Piston: 56 Standard / Drilled
Spring: Red Unthread shock ends 1 turn
Limiters: Inside- none Outside-

Tires
Front: Directionals
Rear: T-2000

Compound
Silver
Red

Foam
Losi Firm
Bomb 2 Firm

Motor: 10x2 Pinion/Spur: 17 86
Battery Position: Middle

Notes: _____