

Setup Sheet

Track: Cactus Classic SRS, AZ

Driver: Matt Francis

Indoor
 Outdoor

Smooth
 Rough

Slippery
 High-Bite
 Blue-Groove

Date: March 25, 2001

Tight / Open

FRONT SUSPENSION *(Circle or Check the Appropriate Settings)*

Toe In 0 °
 Out

Ride Height Arms Level

Camber - 1/2 °
 +

Caster Stock
 Other

Sway Bar No
 Yes size

of washers under steering / tie-rod ball studs
Spindle ball stud: .060
Bellcrank ball stud: 0

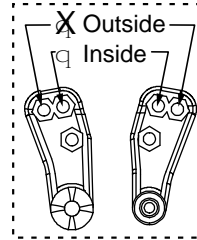

of washers under ball stud: .030

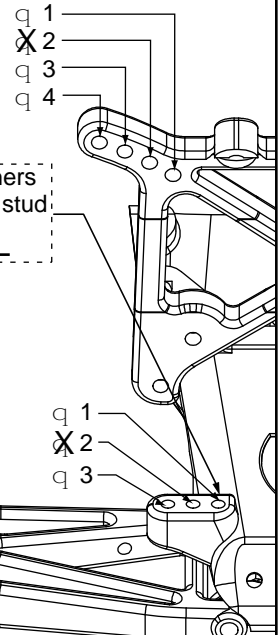

Front Shocks

Oil: 20 wt Losi

Piston: 57 Standard / Drilled

Spring: Red

Limiters: Inside- B Spacer Outside- none

Spindle Location

Top
 Middle
 Bottom

REAR SUSPENSION

Toe-In Inside 3 °
 Outside

Pivot Support 2 deg No Shim
 Shim Under Front Shim Under Rear > # of shims: _____

Ride Height Bones Level

Camber - 1/2 °
 +

Drive Shafts Dogbones Aluminum
 CVDs Steel

Rear Hub Spacing Forward
 Center
 Rear

Outdrives Steel
 Plastic

Sway Bar No
 Yes size

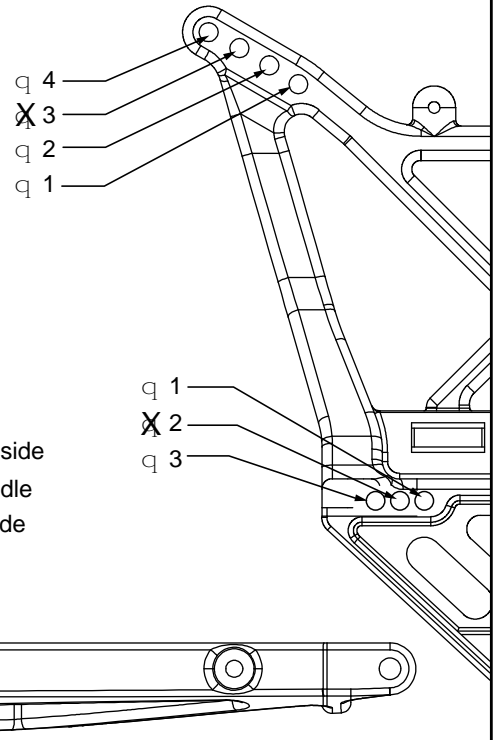

Rear Shocks

Oil: 20 wt Losi

Piston: 56 Standard / Drilled

Spring: Yellow Unthread shock ends 3 turns

Limiters: Inside- none Outside- ends 3 turns

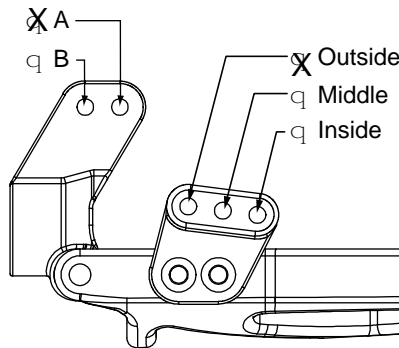

Tires
Front: 8-Rows
Rear: Taper Pin

Compound
Silver
Red

Foam
Losi Firm
Bomb 2 Firm

Motor: 11x2 Pinion/Spur: 18 86
Battery Position: 1/2" back

Notes: _____