



Setup Sheet

Track: French Championship - Round 5

Driver: Frédéric Pain

Date: October 7th 2001

- | | | |
|---|--|---|
| <input type="checkbox"/> Indoor | <input checked="" type="checkbox"/> Smooth | <input type="checkbox"/> Slippery |
| <input checked="" type="checkbox"/> Outdoor | <input type="checkbox"/> Rough | <input checked="" type="checkbox"/> High-Bite |
| <input type="checkbox"/> Tight / <input checked="" type="checkbox"/> Open | | <input type="checkbox"/> Blue-Groove |

FRONT SUSPENSION *(Circle or Check the Appropriate Settings)*

Toe In 0°
 Out 0°

Ride Height Arms Level

Camber - 1°
 + 1°

Caster Stock 0°
 Other _____

Sway Bar No
 Yes size _____

of washers under steering / tie-rod ball studs
Spindle ball stud: 0
Bellcrank ball stud: 0

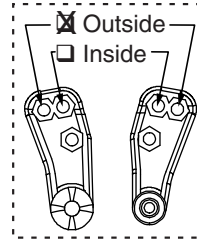

of washers under ball stud: 2

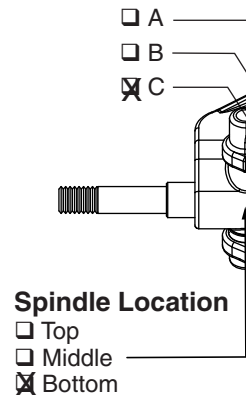
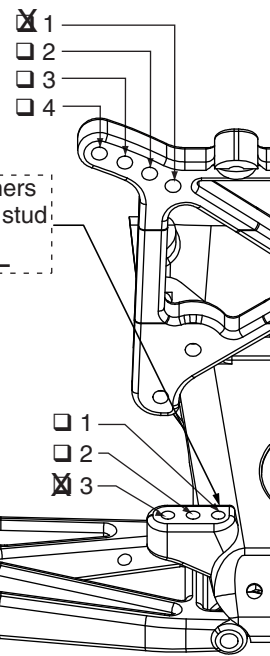

Front Shocks

Oil: 35

Piston Standard Drilled Orange

Spring: Red

Limiters: Inside Outside- none

REAR SUSPENSION

Toe-In Inside 3°
 Outside _____

Pivot Support 1 No Shim
 Shim Under Front
 Shim Under Rear > # of shims: 1

Ride Height Bones slightly above level

Camber - 1°
 + 1°

Rear Hub Spacing Forward
 Center
 Rear

Sway Bar No
 Yes size _____

Drive Shafts Dogbones Aluminum
 CVDs Steel

Outdrives Steel
 Plastic

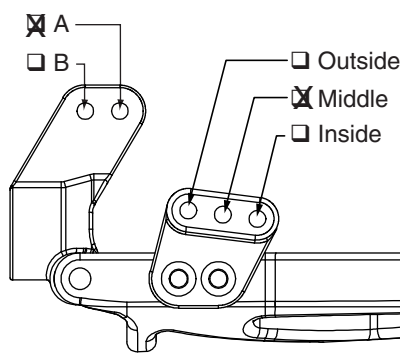
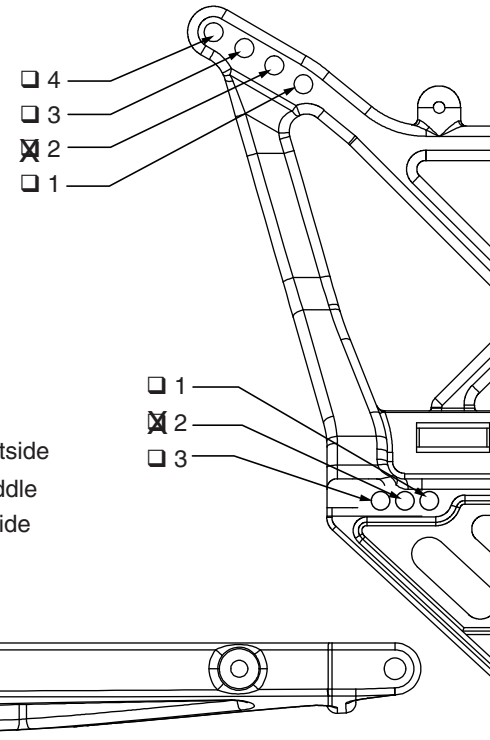

Rear Shocks

Oil: 25

Piston Standard Drilled Orange

Spring: Red

Limiters: Inside Outside- none

Tires
Front: Schum Mini Spike
Rear: Yokomo

Compound _____
Foam _____

Motor: Orion 10x3 Pinion/Spur: / _____
Battery Position: Foward

Notes: _____