

Setup Sheet

Track: Dalton Raceway ROAR Nats

Driver: Matt Francis

Indoor
 Outdoor

Smooth
 Rough

Slippery
 High-Bite
 Blue-Groove

Date: August 20, 2000

Tight / Open

FRONT SUSPENSION *(Circle or Check the Appropriate Settings)*

Toe In 1 °
 Out

Ride Height Arms below level

Camber - 1/2 °
 +

Caster Stock
 Other

Sway Bar No
 Yes size

of washers under steering / tie-rod ball studs
Spindle ball stud: 2
Bellcrank ball stud: 0

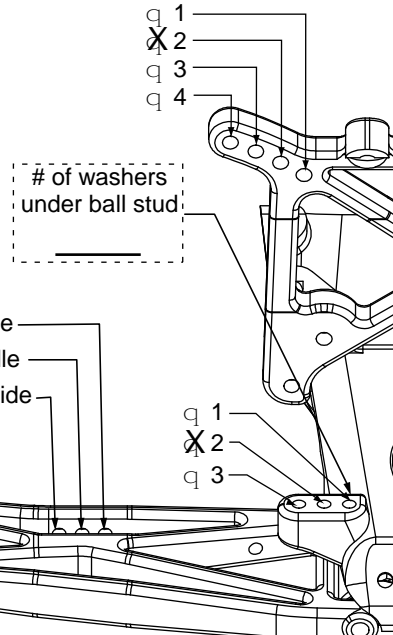
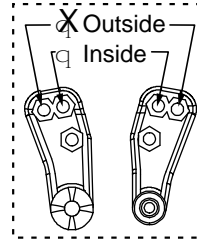

Front Shocks

Oil: 25 wt Losi
Piston: 57 Standard / Drilled
Spring: Buggy Green
Limiters: Inside- .170 Outside- 0

Spindle Location

Top
 Middle
 Bottom

REAR SUSPENSION

Toe-In Inside 3 °
 Outside

Pivot Support 1 No Shim
 Shim Under Front
 Shim Under Rear > # of shims: _____

Ride Height Bones below level

Camber - 1/2 °
 +

Drive Shafts Dogbones Aluminum
 CVDs Steel

Rear Hub Spacing Forward
 Center
 Rear

Outdrives Steel
 Plastic

Sway Bar No
 Yes size

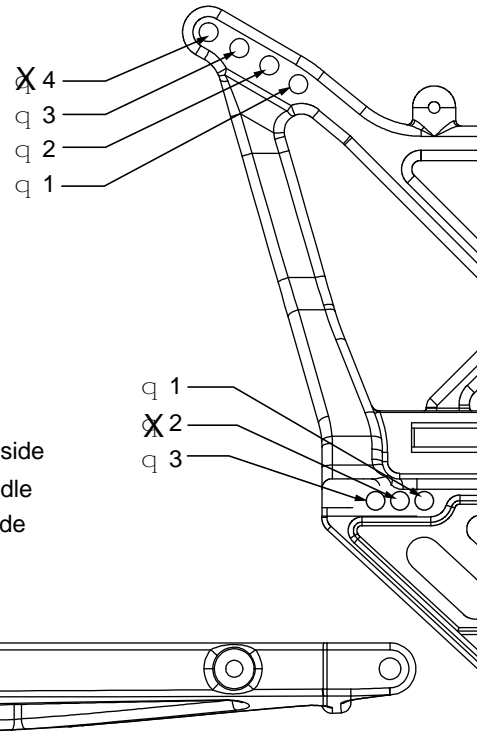

Rear Shocks

Oil: 35 wt Losi
Piston: 55 Standard / Drilled
Spring: Yellow (Shock end unscrewed 4 turns)
Limiters: Inside- 0 Outside- 0

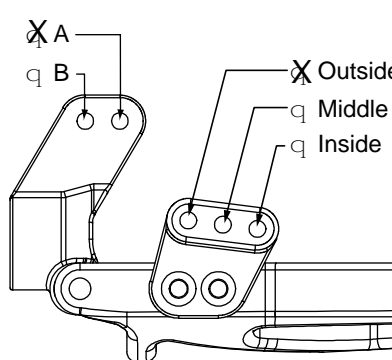

Tires	Compound	Foam
Front: <u>Taper Pin</u>	<u>Silver</u>	<u>Trinity Blue</u>
Rear: <u>Taper Pin</u>	<u>Silver</u>	<u>Trinity Blue</u>

Motor: 11x2 Pinion/Spur: 21 100
Losi Gear 19/88
Battery Position: 1/2" Back

Notes: 1 oz. weight in front bulkhead