

Name: <u>Mike Truhe</u>	Date: <u>Aug. 2010</u>	Event: <u>ROAR Nationals</u>
City: _____ State: <u>IL.</u>	Track: <u>LHR</u>	
Track <input type="checkbox"/> Indoor <input type="checkbox"/> Tight <input type="checkbox"/> Smooth <input checked="" type="checkbox"/> Hard Packed <input type="checkbox"/> Blue Groove <input type="checkbox"/> Wet <input type="checkbox"/> Low Bite <input type="checkbox"/> High Bite Conditions <input checked="" type="checkbox"/> Outdoor <input checked="" type="checkbox"/> Open <input type="checkbox"/> Rough <input type="checkbox"/> Loose/Loamy <input type="checkbox"/> Dry <input type="checkbox"/> Dusty <input checked="" type="checkbox"/> Med Bite <input type="checkbox"/> Other _____		

Front Suspension

Toe: 1/2* out
 Ride Height: 24mm
 Camber: -1*
 Caster: Stock 30*
 Sway Bar: no
 Oil: Losi 27.5wt
 Piston: 56
 Spring: Orange
 Limiters: no limiters, unscrewed 2 turns
 Spindle Height: down
 Axle Spacer: narrow
 Steering Type: bellcrank
 Bump Steer: 0
 Camber Link: 3-B with 3 washers
 Shock Location: 3-outside
 VLA: long
 Front Wing: no

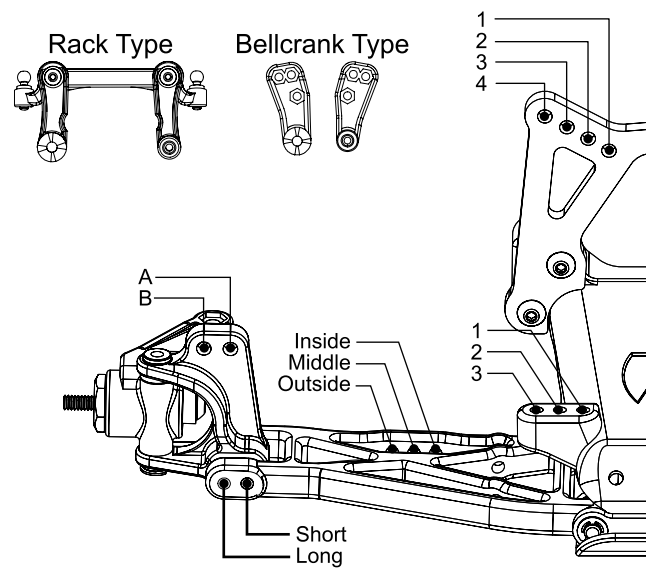

Notes: Shock tower lowered .070

Rear Suspension

Toe: 3
 Pivot Support: XXX raised .060 front and .050 rear
 Ride Height: 23mm
 Camber: -1.5*
 Rear Hub Spacing: All the way back.
 Drive Shafts/Outdrives: CVD's / Steel outdrives
 Sway Bar: no
 Oil: Losi 27.5wt
 Piston: 56
 Spring: White
 Limiters: .050
 Camber Link: 3-B with 4 washers on Trinity hub.
 Shock Location: 1- inside
 VLA: Short
 Wing Position/Mount: Low
 Body & Wing Type: XXX body with high down force wing
 Battery Position: forward

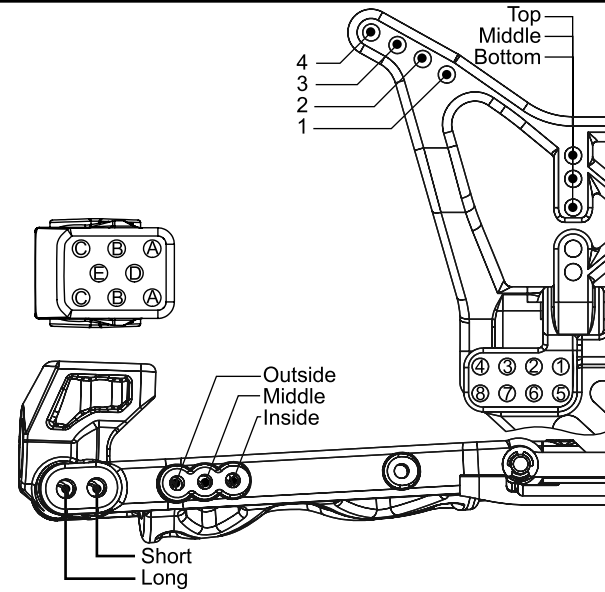

Notes: Arms ground to move the hubs back an extra .030.

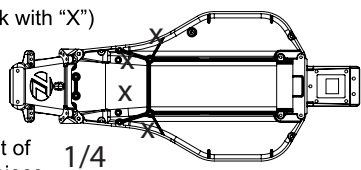
Weight Placement (Mark with "X")  Weight of each piece <u>1/4</u> oz.	Tires: _____	Type <u>7202</u>	Compound <u>Red</u>	Insert <u>Stock</u>	Additive <u>no</u>	Motor: <u>7.5</u>
	Front: _____					Spur: <u>78</u>
	Rear: _____		<u>Red</u>	<u>Bomb 1</u>	<u>no</u>	Pinon: <u>23</u>
	Notes: _____					