

TEKINS SETUP SHEET XXX CR

Name: Ian Southwell Date: 15-11-08 Event: MKGP
 City: Newbury State: _____ Track: Newbury indoor
 Track Indoor Tight Smooth Hard Packed Blue Groove Wet Low Bite High Bite
 Conditions Outdoor Open Rough Loose/Loamy Dry Dusty Med Bite Other _____

Front Suspension

Toe: -1
 Ride Height: Wishbones below level
 Camber: -1
 Caster: STD
 Sway Bar: -
 Oil: 35
 Piston: Red
 Spring: Red Green
 Limiters: -
 Spindle Height: STD
 Axle Spacer: STD
 Steering Type: Rack
 Bump Steer: one gold washer
 Camber Link: A-1-one washer
 Shock Location: Inside-3
 VLA: long
 Front Wing: -

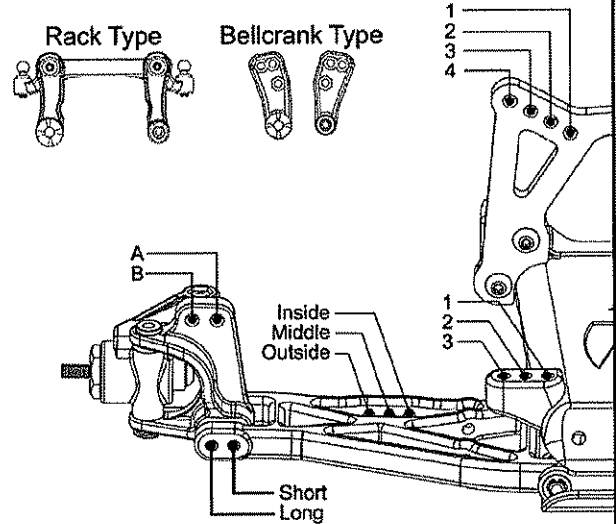

Notes: _____

Rear Suspension

Toe: STD
 Pivot Support: STD
 Ride Height: Drive shafts below level
 Camber: -1.5
 Rear Hub Spacing: medium
 Drive Shafts/Outdrives: Daybones
 Sway Bar: -
 Oil: 27.5
 Piston: Red
 Spring: Orange
 Limiters: -
 Camber Link: B forwards -3
 Shock Location: 3 outside
 VLA: Short
 Wing Position/Mount: Low
 Body & Wing Type: _____
 Battery Position: Forward

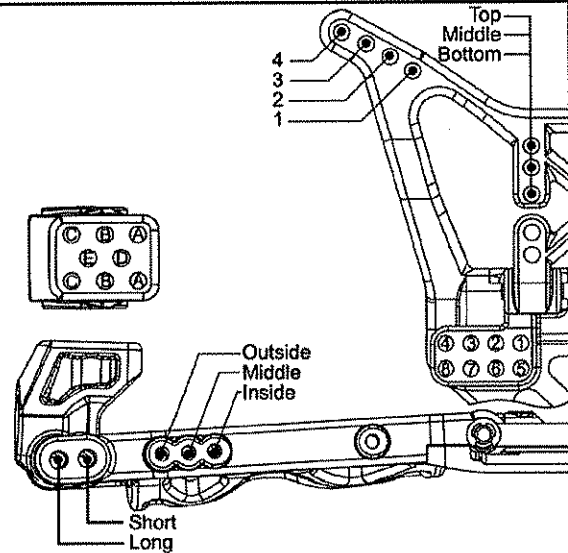

Notes: _____

Weight Placement
(Mark with "X")

Weight of each piece: 2.0 oz.

Tires: Type Compound Insert Additive Motor: 6.5
 Front: mini pin yellow med Spur: 78
 Rear: _____ Pinion: 23
 Notes: Awesome when warmer, slippy when cold.
I dropped down a spring rate when it was colder.