

Name: <u>dexter smith</u>		Date: <u>7/8/2007</u>	Event: _____
City: _____	State: _____	Track: _____	
Track <input checked="" type="checkbox"/> Indoor <input checked="" type="checkbox"/> Tight <input checked="" type="checkbox"/> Smooth <input checked="" type="checkbox"/> Hard Packed <input type="checkbox"/> Blue Groove <input checked="" type="checkbox"/> Wet <input type="checkbox"/> Low Bite <input checked="" type="checkbox"/> High Bite Conditions <input type="checkbox"/> Outdoor <input type="checkbox"/> Open <input type="checkbox"/> Rough <input type="checkbox"/> Loose/Loamy <input type="checkbox"/> Dry <input type="checkbox"/> Dusty <input type="checkbox"/> Med Bite <input checked="" type="checkbox"/> Other <b>CLAY</b>			

## Front Suspension

Toe: 0° Toe  
 Ride Height: ARMS LEVEL  
 Camber: -1°  
 Caster: 25°  
 Sway Bar: no  
 Oil: 25  
 Piston: 56  
 Spring: orange  
 Limiters: 0  
 Spindle Height: bottom  
 Axle Spacer: narrow  
 Steering Type: \_\_\_\_\_  
 Bump Steer: .030  
 Camber Link: 2A/1  
 Shock Location: 2-outside  
 VLA: long  
 Front Wing: none

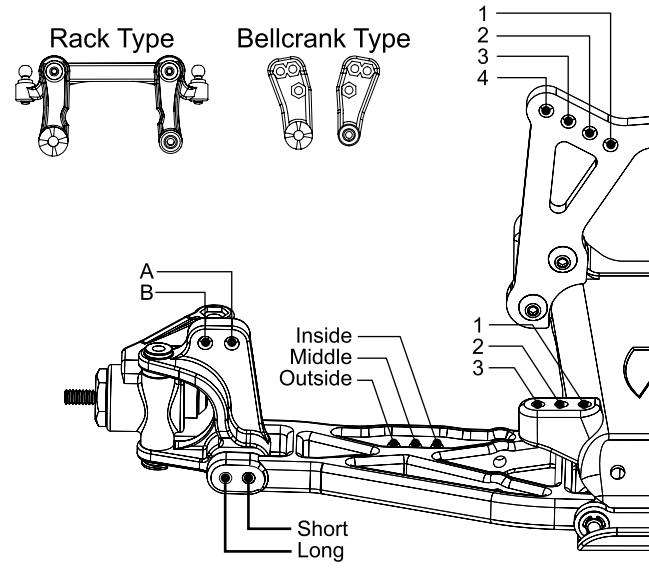

Notes: UNSREW 2 TURNS

\_\_\_\_\_

\_\_\_\_\_

## Rear Suspension

Toe: 3° Block, 0° Hubs  
 Pivot Support: 2° Pivot, 0 Shims (2° total)  
 Ride Height: ARMS LEVEL  
 Camber: -1°  
 Rear Hub Spacing: back°  
 Drive Shafts/Outdrives: steel bones/steel outdrives  
 Sway Bar: no  
 Oil: 25  
 Piston: 57  
 Spring: white  
 Limiters: .090  
 Camber Link: 2B/3  
 Shock Location: 2-middle  
 VLA: short  
 Wing Position/Mount: Forward/Bottom  
 Body & Wing Type: XXX-CR/XXX-CR (Dual Wing)  
 Battery Position: Forward

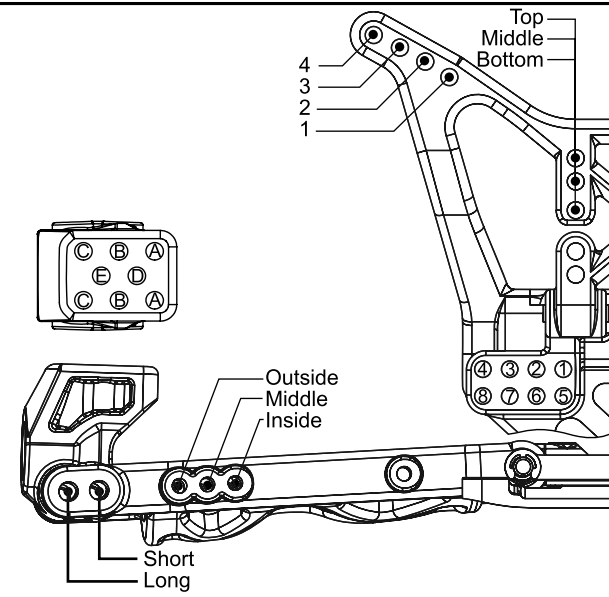

Notes: \_\_\_\_\_

\_\_\_\_\_

\_\_\_\_\_

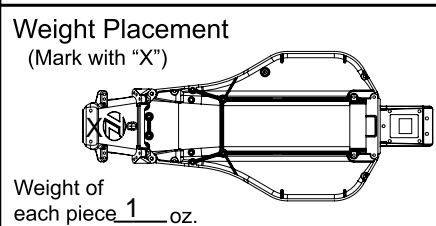

Tires: Type \_\_\_\_\_ Compound \_\_\_\_\_ Insert \_\_\_\_\_ Additive \_\_\_\_\_ Motor: \_\_\_\_\_  
 Front: PANTHER CLAY PANTHER CLAY BOMB 1 \_\_\_\_\_ Spur: 78  
 Rear: \_\_\_\_\_ \_\_\_\_\_ \_\_\_\_\_ \_\_\_\_\_ Pinon: 22  
 Notes: \_\_\_\_\_  
 \_\_\_\_\_