

TRIPLE X-CR SETUP SHEET

Name: Brian Preddy Date: 12 April 2009 Event: _____
 City: _____ State: _____ Track: Kidderminster
 Track Indoor Tight Smooth Hard Packed Blue Groove Wet Low Bite High Bite
 Conditions Outdoor Open Rough Loose/Loamy Dry Dusty Med Bite Other _____

Front Suspension

Toe: 0 degree
 Ride Height: 23mm
 Camber: -1 degree
 Caster: 30 degree
 Sway Bar: None
 Oil: 35 wt
 Piston: Red
 Spring: Green
 Limiters: None (Inside and Outside)
 Spindle Height: Low
 Axle Spacer: Narrow
 Steering Type: Rack
 Bump Steer: None Ackerman washers: None
 Camber Link: 2 - B, 1 gold washer (= 0.03)
 Shock Location: 3 - Middle
 VLA: Short
 Front Wing: None

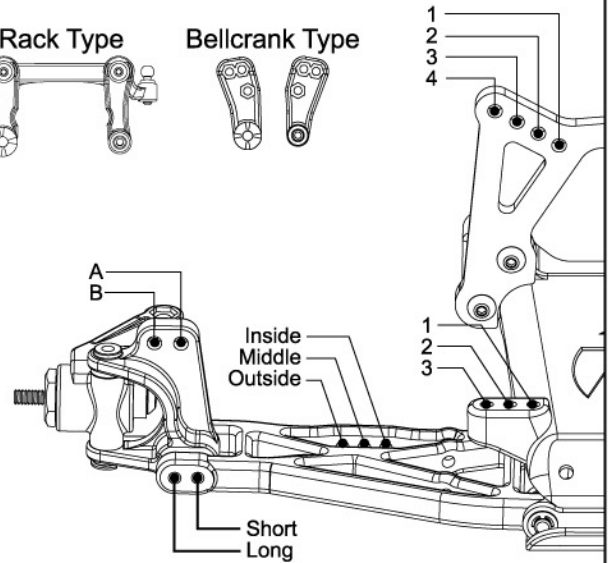
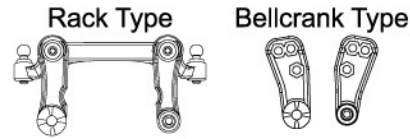

Notes: Brass bulkhead (or 35g)

Rear Suspension

Toe: Pivote: -3 degree - Hub: 0 degree
 Pivot Support: 2 degree, Antisquat: None
 Ride Height: 23 mm
 Camber: -1 degree
 Rear Hub Spacing: Long wheelbase
 Drive Shafts/Outdrives: Losi steel drive shafts
 Sway Bar: None
 Oil: 25 wt
 Piston: Orange (55)
 Spring: Yellow 2.0 (no coils cut)
 Limiters: Inside: None - Outside: None - Unscrewed: 0 turns
 Camber Link: 7 - E Ballstud washers: 0.09
 Shock Location: 3 - Outside
 VLA: long
 Wing Position/Mount: Standard / Bottom
 Body & Wing Type: TripleX-CR - A8110 High Down force
 Battery Position: Forward

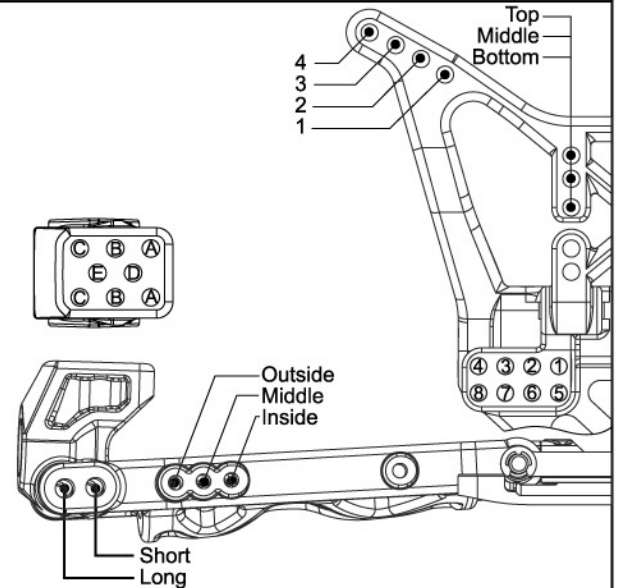

Notes: _____

Weight Placement
(Mark with "X")

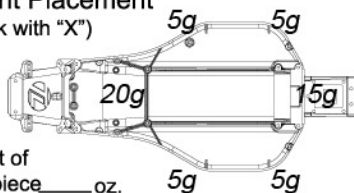

Weight of each piece _____ oz.

Tires: Type Compound Insert Additive Motor: 7.5t Losi
 Front: Schumacher Mini Spike green Losi fir Spur: 78 T
 Rear: Schumacher Mini Spike green Mr O Blue Pinon: 26
 Notes: Short Ko Propo servo, lipo setup with the car weighing 1545g
would only run rear shocks on inside hole on the wishbone when car is lacking drive

am0(@)petitrc.com