

TEMPO SETUP SHEET XXX-CR

Name: Brian Preddy Date: _____ Event: _____
 City: _____ State: _____ Track: _____
 Track Conditions: Indoor Tight Smooth Hard Packed Blue Groove Wet Low Bite High Bite
 Outdoor Open Rough Loose/Loamy Dry Dusty Med Bite Other _____

Front Suspension

Toe: _____ 0 deg
 Ride Height: _____ 23 mm
 Camber: _____ -1 deg
 Caster: _____ 30 deg
 Sway Bar: _____ None
 Oil: _____ 35 wt
 Piston: _____ 56 Red Other: _____
 Spring: No Coils Cut Green 3.5
 Limiters: _____ Inside None / Outside None
 Spindle Height: _____ Low
 Axle Spacer: _____ Narrow
 Steering Type: _____ Rack
 Bump Steer: None / Ackerman Washers: None
 Camber Link: 2 - B Ball Stud Washers: 0.03
 Shock Location: _____ 3 - Middle
 VLA: _____ Short
 Front Wing: _____ None

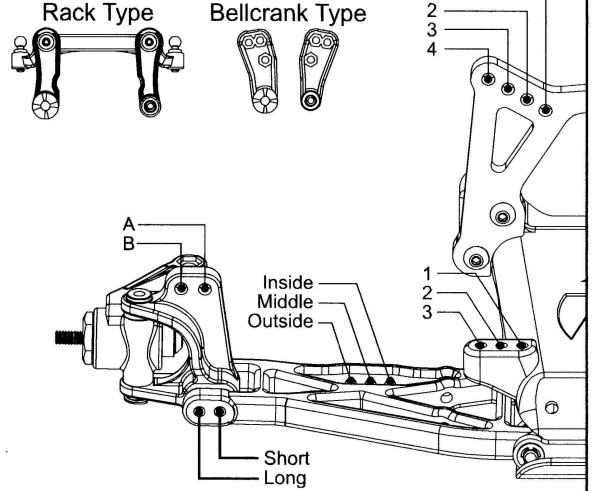

Notes: Ghea brass front bulkhead 35g

Rear Suspension

Toe: _____ Pivot -3 Hub 0
 Pivot Support: 2 deg Anti-Squat 0.01 Under Rear
 Ride Height: _____ 23 mm
 Camber: _____ -1 deg
 Rear Hub Spacing: _____ Middle
 Drive Shafts/Outdrives: Univer. Steel / Steel
 Sway Bar: _____ None
 Oil: _____ 25 wt
 Piston: _____ 55 Orange Other: _____
 Spring: No Coils Cut Yellow 2.0
 Limiters: Inside None / Outside None / Unscrewed 0 Turns
 Camber Link: 7 - E Ball Stud Washers: 0.09
 Shock Location: _____ 3 Outside
 VLA: _____ Long
 Wing Position/Mount: Standard / Bottom
 Body & Wing Type: XXX-CR / Aurora hd
 Battery Position: Front

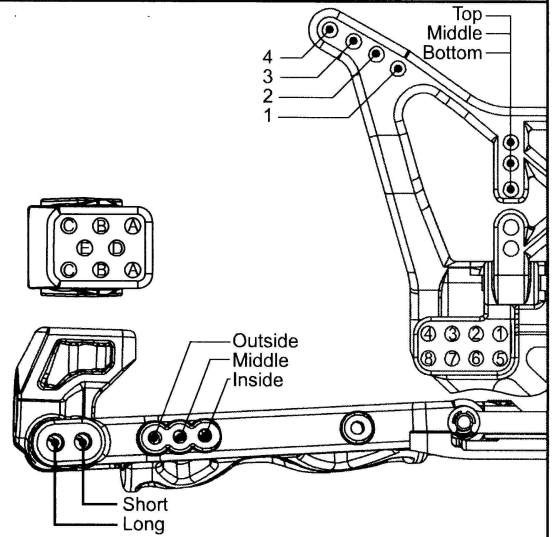

Notes: _____

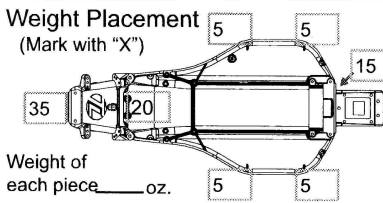

Tires: Type _____ Compound _____ Insert _____ Additive _____ Motor: Losi 7.5
 Front: _____ Spur: 78 T
 Rear: _____ Pinon: 27
 Notes: Car weights in at 1545g setup is for lipo