

TENSON SETUP SHEET XXX-CR

Name: <u>Tom Cockerill</u>	Date: _____
City: <u>Batley</u> State: <u>UK</u>	Track: _____
Track <input checked="" type="checkbox"/> Indoor <input type="checkbox"/> Tight <input type="checkbox"/> Smooth <input type="checkbox"/> Hard Packed <input type="checkbox"/> Blue Groove <input type="checkbox"/> Wet <input type="checkbox"/> Low Bite <input type="checkbox"/> High Bite Conditions <input type="checkbox"/> Outdoor <input type="checkbox"/> Open <input type="checkbox"/> Rough <input type="checkbox"/> Loose/Loamy <input type="checkbox"/> Dry <input type="checkbox"/> Dusty <input type="checkbox"/> Med Bite <input type="checkbox"/> Other _____	

Front Suspension

Toe: Out
 Ride Height: Chassis Level with Rear
 Camber: -1 Deg
 Caster: Standard
 Sway Bar: No
 Oil: 35 Wt
 Piston: Orange
 Spring: Blue
 Limiters: None
 Spindle Height: Low
 Axle Spacer: Inside
 Steering Type: Rack
 Bump Steer: 0
 Camber Link: B/2
 Shock Location: Middle/4
 VLA: Long
 Front Wing: Yes

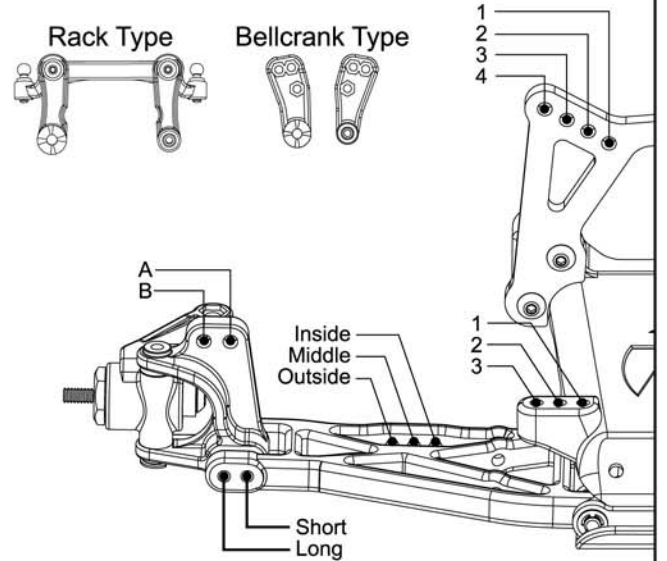

Notes: 15g In Blukhead

Rear Suspension

Toe: -3 Deg Inboard
 Pivot Support: Standard
 Ride Height: Driveshaft just below level
 Camber: -1 Deg
 Rear Hub Spacing: Middle
 Drive Shafts/Outdrives: Steel Dogbone/Steel Outdrives
 Sway Bar: None
 Oil: 30 Wt
 Piston: Red
 Spring: Yellow
 Limiters: Inside 0/Outside 0
 Camber Link: E/2 + Gold washers under the ball stud
 Shock Location: Middle/2
 VLA: Short
 Wing Position/Mount: Middle
 Body & Wing Type: XXX-CR
 Battery Position: Forward

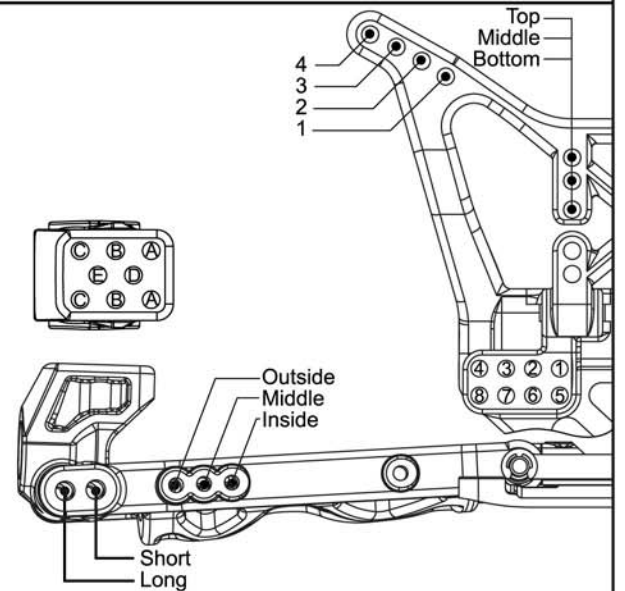

Notes: _____

Weight Placement
(Mark with "X")

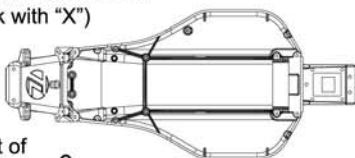

Weight of each piece 0 oz.

Tires:	Type	Compound	Insert	Additive	Motor: _____
Front:	_____	_____	_____	_____	Spur: _____
Rear:	_____	_____	_____	_____	Pinon: _____
Notes:	_____				