

TENSON SETUP SHEET XXX CR

Name: Richard Taylor Date: _____ Event: Club
 City: _____ State: _____ Track: Bury Metro
 Track Indoor Tight Smooth Hard Packed Blue Groove Wet Low Bite High Bite
 Conditions Outdoor Open Rough Loose/Loamy Dry Dusty Med Bite Other _____

Front Suspension

Toe: -1 Deg
 Ride Height: Arm Level
 Camber: -1 Deg
 Caster: 30 Stock
 Sway Bar: N/A
 Oil: 32.5
 Piston: ORA
 Spring: Blue
 Limiters: None
 Spindle Height: Bottom
 Axle Spacer: Narrow
 Steering Type: Rack
 Bump Steer: None
 Camber Link: A/2
 Shock Location: 3/Middle
 VLA: Long
 Front Wing: No

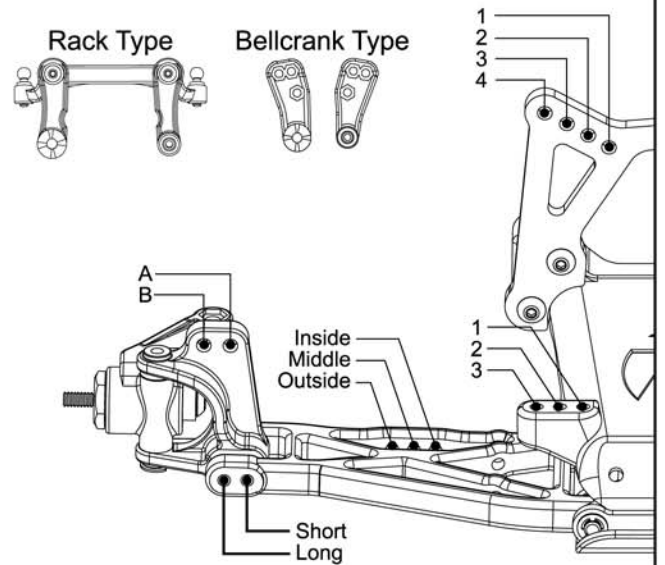

Notes: _____

Rear Suspension

Toe: 3 Deg
 Pivot Support: 0 Deg/1 Washer
 Ride Height: D/S Level
 Camber: -1 Deg
 Rear Hub Spacing: Middle
 Drive Shafts/Outdrives: Steel
 Sway Bar: None
 Oil: 45
 Piston: Blue
 Spring: Yellow/2 Coils Removed
 Limiters: A Spacer
 Camber Link: B/2
 Shock Location: 2/Inside
 VLA: Short
 Wing Position/Mount: Bottom
 Body & Wing Type: CR Type
 Battery Position: Against Servo

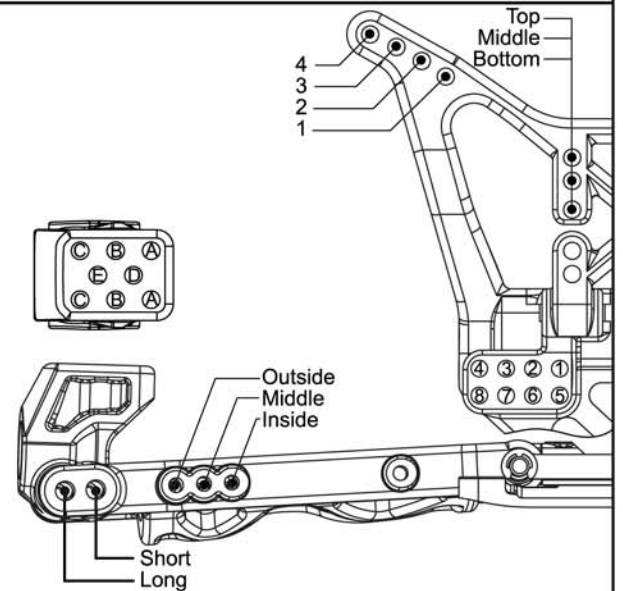

Notes: _____

Weight Placement
(Mark with "X")

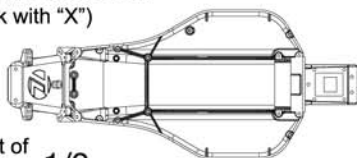

Weight of each piece 1/2 oz.

Tires: Type SCH Compound Yellow Insert Losi Additive _____ Motor: 2 Star
 Front: _____ Spur: 82
 Rear: SCH Yellow Losi _____ Pinon: 18
 Notes: 25g Behind Battery Foam