

TENLOS SETUP SHEET XXX-CR

Name: Brandon Rohde

Date: 10/15/2006

Event: Standard Setup for Dirt Heav

City: New Franken State: WI

Track: Dirt Heaven Hobby & Raceway

Track Indoor Tight Smooth Hard Packed Blue Groove Wet Low Bite High Bite
 Conditions Outdoor Open Rough Loose/Loamy Dry Dusty Med Bite Other _____

Front Suspension

Toe: 0.5° Toe-In
 Ride Height: 23mm
 Camber: -1°
 Caster: 25°
 Sway Bar: no
 Oil: 30
 Piston: 56
 Spring: orange
 Limiters: 0
 Spindle Height: bottom
 Axle Spacer: narrow
 Steering Type: _____
 Bump Steer: .030
 Camber Link: 2A/0
 Shock Location: 2-middle
 VLA: long
 Front Wing: none

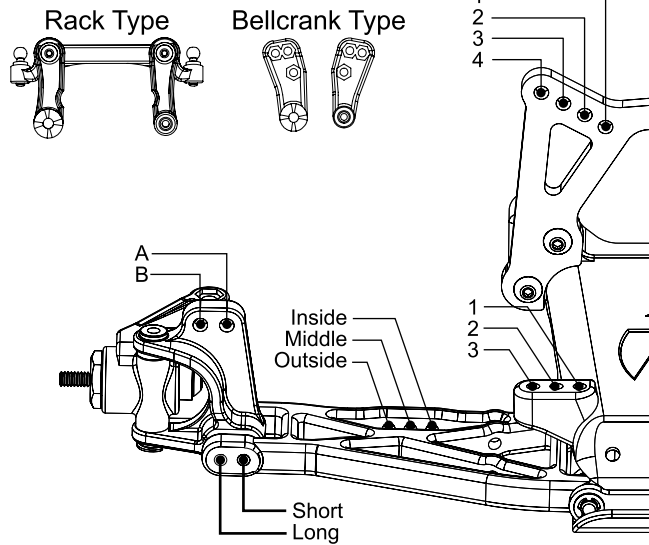

Notes: _____

Rear Suspension

Toe: 3° Block, 0° Hubs
 Pivot Support: 2° Pivot, 1 Shims (3° total)
 Ride Height: 24mm
 Camber: -1°
 Rear Hub Spacing: 1/4 back (.030 front, .090 back)
 Drive Shafts/Outdrives: steel bones/steel outdrives
 Sway Bar: no
 Oil: 17.5
 Piston: 57
 Spring: white
 Limiters: .090
 Camber Link: 3B/4
 Shock Location: 2-middle
 VLA: short
 Wing Position/Mount: Forward/Bottom
 Body & Wing Type: XXX-CR/XXX-CR (Dual Wing)
 Battery Position: Forward

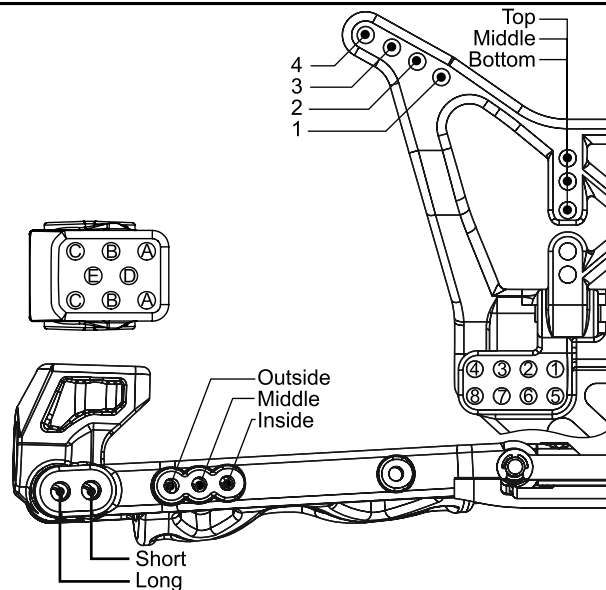

Notes: _____

Weight Placement
(Mark with "X")

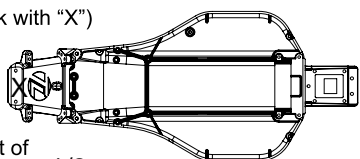

Weight of each piece 1/2 oz.

Tires:	Type	Compound	Insert	Additive	Motor: <u>14x2</u>
Front:	<u>Cut Evil Twin</u>	<u>R3</u>	<u>3/4 Gray</u>		Spur: <u>78</u>
Rear:	<u>Taper Pin</u>	<u>Pink</u>	<u>Gray</u>		Pinon: <u>23</u>

Notes: Super aggressive steering setup. Hard to drive, but its fast