



Offert par www.petitrc.fr.st

Setup Sheet

Track: Limoges - 5 Round French Champ

Driver: Stéphane RONGIER

Date: 08 / 10 / 2000

- | | | |
|---|--|---|
| <input type="checkbox"/> Indoor | <input checked="" type="checkbox"/> Smooth | <input type="checkbox"/> Slippery |
| <input checked="" type="checkbox"/> Outdoor | <input type="checkbox"/> Rough | <input checked="" type="checkbox"/> High-Bite |
| <input type="checkbox"/> Tight / <input checked="" type="checkbox"/> Open | | <input type="checkbox"/> Blue-Groove |

FRONT SUSPENSION

(Circle or Check the Appropriate Settings)

Toe In Out 0 °

Ride Height Drive shaft level

Camber - + 0.5 °

Caster Stock Other °

Sway Bar No Yes size

of washers under steering / tie-rod ball studs
 Spindle ball stud: /
 Bellcrank ball stud: /

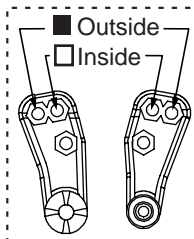

of washers under ball stud: 1

- 1
- 2
- 3

Front Shocks

Oil: 25

Piston: 7 / 7 / 6 Standard / Drilled

Spring: Green

Limiters: Inside- / Outside- /

Spindle Height

- Top
- Middle
- Bottom

Axle Spacer

- Narrow - inside
- Wide - outside

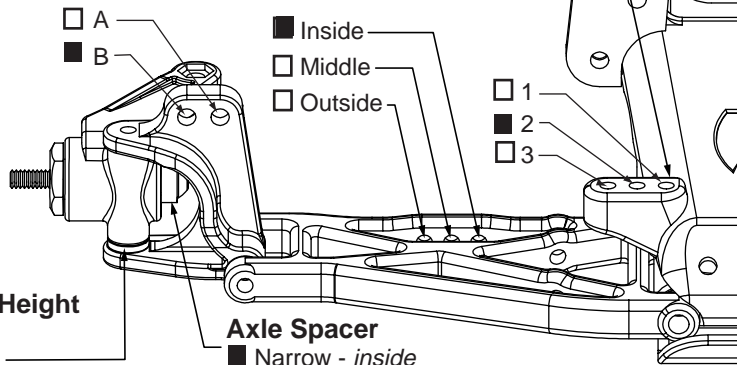

REAR SUSPENSION

Toe-In Inside 3 ° Outside °

Pivot Support 2° No Shim Shim Under Front Shim Under Rear } # of shims: 1

Ride Height Dogs levels

Camber - + 1 °

Rear Hub Spacing Forward Center Rear

Sway Bar No Yes size

Drive Shafts Dogbones Aluminum CVDs Steel

Outdrives Steel Plastic

Wing Position

- Forward
- Back

Wing Mount

- Top
- Bottom

- 4
- 3
- 2
- 1

- 1
- 2
- 3

Rear Shocks

Oil: 27.5

Piston: 56 Standard / Drilled

Spring: Red

Limiters: Inside- A Outside-

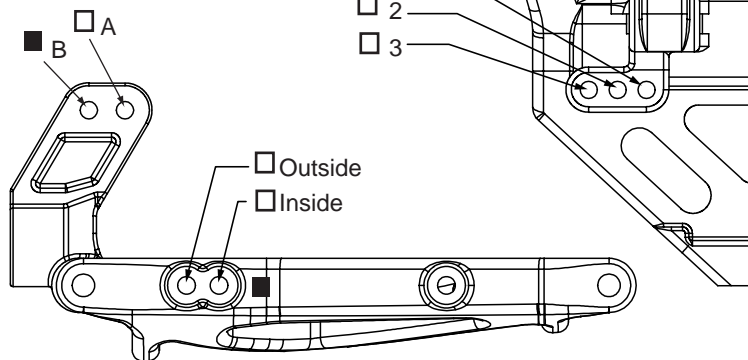

Tires

Front: Xtra Wide Body

Rear: Pro-Line 8186 "Bow Tie"

Compound

Silver

M2

Foam

Std

Std

Motor: Fusion 8 x3 Pinion/Spur: 20 / 84

Battery Position: Middle

Notes: 10 Grs in the bulkhead - Front Wind used - TQ and 3rd place - Team LRP / LOSI