

Name: _____	Date: _____ Event: _____
City: _____ State: _____	Track: _____

Track Conditions	<input type="checkbox"/> Indoor	<input type="checkbox"/> Tight	<input type="checkbox"/> Smooth	<input type="checkbox"/> Hard Packed	<input type="checkbox"/> Blue Groove	<input type="checkbox"/> Wet	<input type="checkbox"/> Low Bite	<input type="checkbox"/> High Bite
	<input type="checkbox"/> Outdoor	<input type="checkbox"/> Open	<input type="checkbox"/> Rough	<input type="checkbox"/> Loose/Loamy	<input type="checkbox"/> Dry	<input type="checkbox"/> Dusty	<input type="checkbox"/> Med Bite	<input type="checkbox"/> Other _____

Front Suspension

Toe: _____

Ride Height: _____

Camber: _____

Caster: _____

Sway Bar: _____

Piston/Oil: _____

Spring: _____

Limiters/Droop: _____

Overall Shock Length: _____

Steering Ackerman: _____

Bump Steer: _____

Camber Link: _____

Shock Location: _____

Front Diff Fluid: _____

Receiver Battery Type: _____

Center Diff Fluid: _____

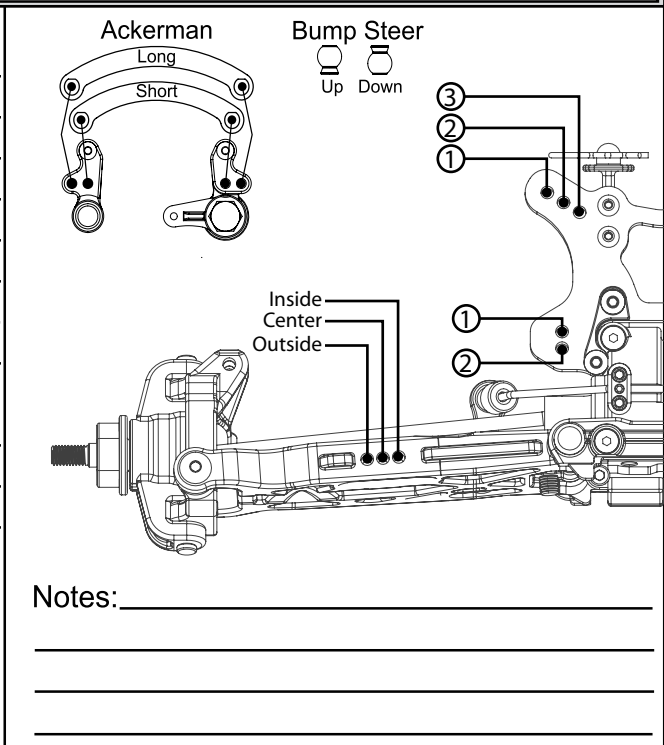

Rear Suspension

Toe: _____

Anti-Squat: _____

Ride Height: _____

Camber: _____

Rear Hub Spacing: _____

Sway Bar: _____

Piston/Oil: _____

Spring: _____

Limiters/Droop: _____

Overall Shock Length: _____

Camber Link: _____

Shock Location: _____

Rear Diff Fluid: _____

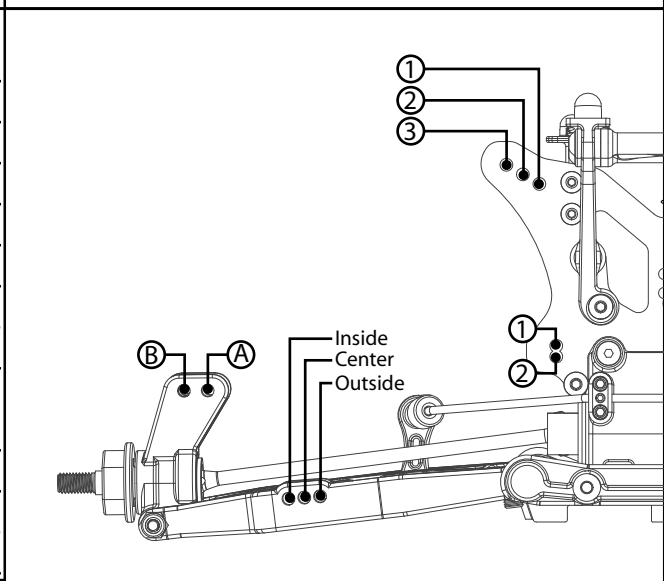

Engine

Engine: _____ Fuel: _____

Glow Plug: _____ Head Clearance: _____

Pipe/Header: _____ Gearing: _____

Notes
