

# TEN-SCTE 2.0 Tuning Tips



Before you start making changes on your TEN-TEN-SCTE 2.0 Off-Road Racing truck, you need to make a few decisions. You will find the best adjustment will become a personal decision based on the “feel” each of these adjustments yield. Never make more than one change at a time. If the change you made works adversely, or doesn’t address your need, return to the previous position and try something else. For the latest in setup and accessory parts information, visit the TLR web site at: [www.TLRacing.com](http://www.TLRacing.com) regularly. Also note that there are many ways to set up a car. The rules we follow can sometimes vary with different driving styles or different setup styles.

## **Droop:**

Always measure the droop of the TEN-TEN-SCTE 2.0 with the shocks on the truck. Droop is always measured from the center of the top shock mount to the center of the bottom shock screw and is usually accomplished with digital calipers for a precise measurement. More droop (travel) in the front has more on-power steering and allows the truck to roll more on the rear when on throttle and increases rear traction when exiting corners. More droop (travel) in the rear increases off-power steering and allows the truck to roll on the front when off throttle. More front and rear droop accelerates better in bumps when going straight, but can cause the truck to traction roll in rough turns. Less front and rear droop slides over bumps better in turns and may be better on high-speed and high traction tracks.

## **Front Camber Links:**

The lower camber link locations on the tower have more camber gain (total camber change through the suspension travel). Running the camber tie rod in the lower holes increases off-power steering and makes the vehicle more aggressive; however, you may lose some consistency. More camber gain is good on small tight tracks. We find that running less camber gain in the front suits the car the best for consistency and steering balance. On the TEN-SCTE 2.0, we also offer the ability to change the length of the camber link. A longer front camber link makes the vehicle feel stiffer, and this keeps the truck flatter with less roll and increases high-speed steering. A short front camber link rolls more and makes the vehicle more aggressive. Too short of a front link may make the vehicle feel twitchy.

## **Rear Camber Links:**

The TEN-SCTE 2.0 has only two vertical rows of camber locations on the rear tower. A longer rear camber link provides less roll and improves stability and traction. A shorter rear camber link has more roll and increases steering and better handling in the bumps. By raising the inner camber link up, you increase the roll stiffness of the vehicle. This can make the vehicle easier to drive, but may reduce corner speed and hurt bump absorption. Running “A” in the rear hub generates more corner rotation entering the turn, but decreases steering on exit. Running “B” in the hub is more stable entering the turn and increases steering on exit.

# TEN-SCTE 2.0 Tuning Tips

## Camber:

More negative camber in the front has more steering and is more responsive. Less negative camber in the front has less steering and is smoother. More negative camber in the rear has less rear traction, but increases on-power steering and is less grabby in bumps. Less negative camber in the rear has more rear traction and makes the rear of the truck stay flatter, but if traction is lost it is more violent. To ensure your TEN-SCTE 2.0 has the correct camber, we recommend using our Losi® Camber Gauge (LOSA99172).

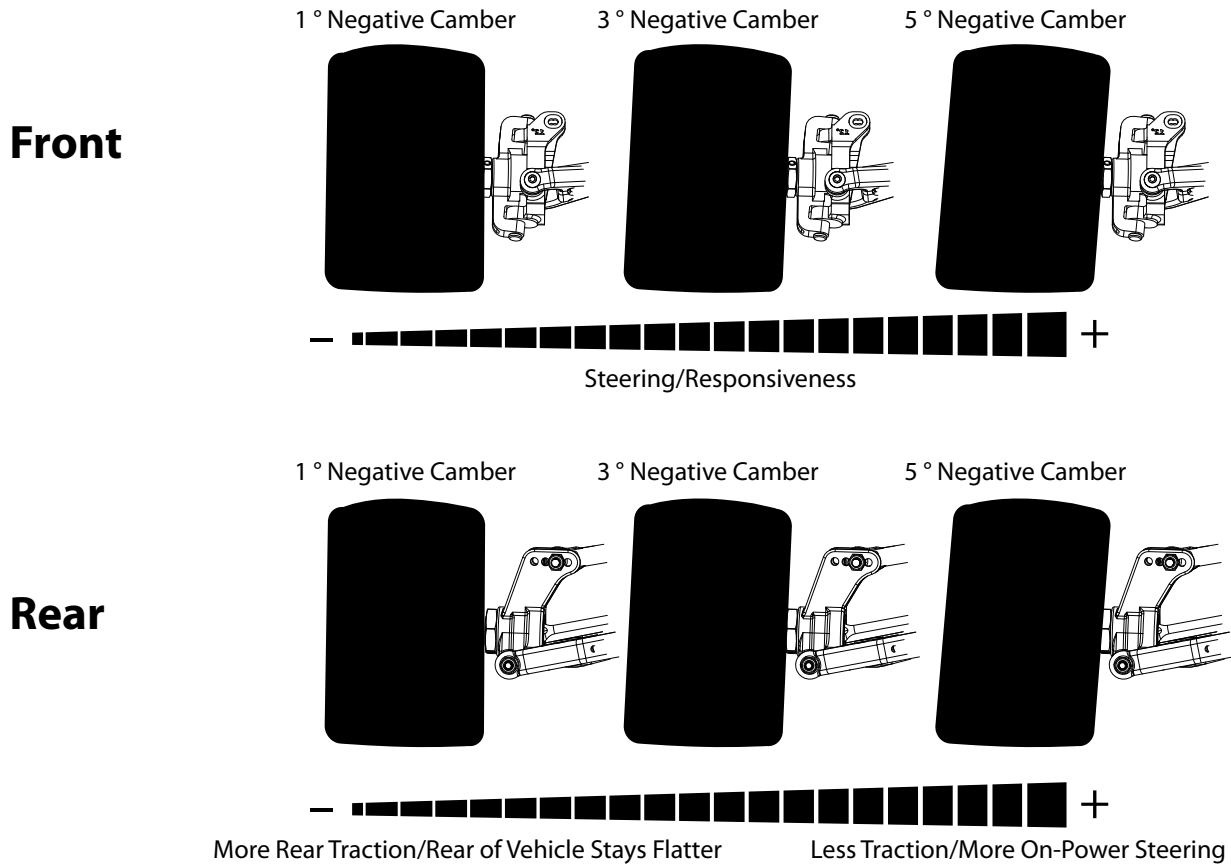

## Front and Rear Adjustable Hinge Pin Braces:

The TEN-SCTE 2.0 is equipped with adjustable front and rear hinge pin braces. The adjustable hinge pin braces allow the angle of the pins on the front of the vehicle to be adjusted for more or less kick, and the rear of the vehicle for more or less toe-in and anti-squat.

## Front Toe:

You never want to run toe-in on the front of the TEN-SCTE 2.0. Front toe-in (longer steering rods) decreases steering response entering in the middle of the turn, but increases on-power steering. Toe-out (shorter steering rods) increases steering response when entering the turn and increases straight line stability; however, it decreases on-power steering.

## Front Kick:

The TEN-SCTE 2.0 comes with 0 inserts in the front and rear. This is a very neutral setup. Increasing the amount of kick has more off-power steering, but decreases on-power steering. Increasing the kick is recommended for low-grip tracks. Decreasing the amount of kick has more on-power steering, but less off-power steering. Decreasing the amount of kick is recommended for high-grip tracks.

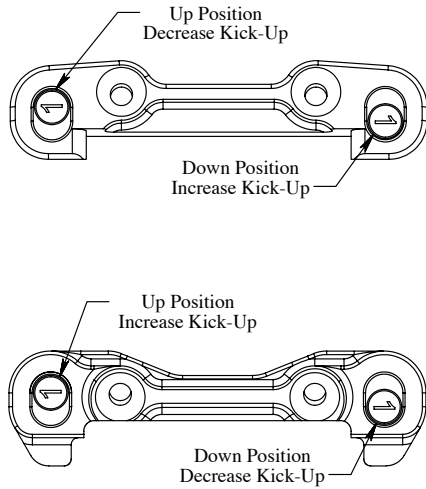

Outer Front Brace		Inner Front Brace		Angle
Insert	Hole Location	Insert	Hole Location	
1	Up	1	Down	12°
0.5	Up	0.5	Down	11°
0	NA	0	NA	10°
0.5	Down	0.5	Up	9°
1	Down	1	Up	8°

## Rear Toe-in:

The TEN-SCTE 2.0 kit setup is with 3 degrees of toe-in per side. Less rear toe-in increases the wheel base of the truck and decreases forward traction, but increases top speed and side traction in the middle of a turn. More toe-in increases forward traction, has more off-power steering and less side traction. This is adjusted by the adjustable hinge pin braces with the different inserts included with the vehicle.

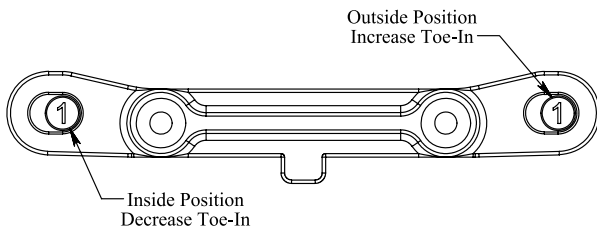

Rear Block		
Insert	Hole Location	Angle
1	In	2°
0.5	In	2.5°
0	NA	3°
0.5	Out	3.5°
1	Out	4°

## Rear Squat:

The TEN-SCTE 2.0 comes with three degrees of anti-squat. Running less anti-squat has less off-power steering and rolls (side to side) more on the rear. Less anti-squat accelerates better in small bumps. More anti-squat has more support (side to side) and is better on rough tracks with big jumps. This is adjusted by the adjustable hinge pin braces with the different inserts included with the vehicle.

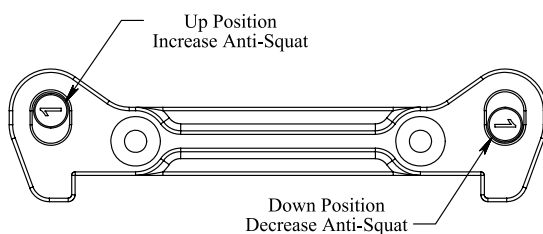

Rear Antisquat Adjustment		
Insert	Hole Location	Angle
1	Up	3°
0.5	Up	2.5°
0	NA	2°
0.5	Down	1.5°
1	Down	1°

# TEN-SCTE 2.0 Tuning Tips

## **Wheel Base:**

The TEN-SCTE 2.0 kit setup is a long wheelbase. A shorter wheelbase (spacers behind the rear hubs) increases on-power traction, rear weight transfer, and has more off-power steering. A shorter wheelbase is better on tight or slick tracks. A longer wheelbase (spacers in front of the rear hubs) decreases off-power steering, is more stable, better in bumps, and has more on-power steering.

## **Sway Bars:**

A thinner front sway bar increases front off-power traction, but has less on-power steering. A thicker front sway bar decreases front off-power traction, making the steering smoother entering the turn, but has more on-power steering. A thinner rear sway bar increases rear traction and decreases on-power steering. A thicker rear sway bar increases stability in the middle of the turn and increases on-power steering. Thicker sway bars are more stable on high-speed, high-traction tracks.

## **Pistons:**

Generally smaller hole pistons have stiffer damping, slower weight transfer, slower response and lands large jumps better. Larger hole pistons have softer damping, increased traction, quicker weight transfer/response and bottom out easier off large jumps.

## **Shock Oil:**

Lighter shock oil has more overall traction and responds quicker. Thicker oil has less overall traction and reacts slower. On high bite/smooth tracks, thicker oil is easier to drive. Make sure you adjust oil when there is a drastic temperature change (10°–12°C) or (20°–25°F). If it gets cold outside, you need to go to lighter shock oil. If it gets hotter outside, you need to go to thicker weight shock oil.

## **Front Shock Mounting Positions:**

Upper—As you move out your steering will be faster and is better on bumpy surfaces.  
Lower—As you move out, you truck will be easier to drive and have better stability.

## **Rear Shock Mounting Positions:**

Upper—As you move out you will have less mid corner grip and more traction into the corner.  
Lower—As you move out you will gain stability and lateral grip in turns. The inside hole will give you more traction exiting a turn.

## **Ackerman:**

The long Ackerman plate has smooth off-power steering and is more forgiving. The long Ackerman plate has more steering on-power. The short Ackerman plate responds quicker and has more steering in the middle of the turn. A short Ackerman plate is better suited for tight technical tracks.

## **Bump Steer:**

Running the bump steer ball down you will have smoother steering in the middle of the turn. With the bump steer ball up, you will increase steering in the middle of the turn.

## **Ride Height:**

This should always be measured from a flat surface to the bottom face of the chassis. Adjust the front of the chassis with 27mm of ride height and 26mm in the rear. On high-speed tracks the TEN-SCTE 2.0 handles best when the front ride height is level to the rear of the truck. To measure your ride height properly, we recommend using the Losi Ride Height Gauge (LOSA99173).

**Front:**

Thinner front differential oil increases off-power steering, but if the oil is too thin the steering becomes grabby and inconsistent. Thicker front differential oil increases off-power stability and increases on-power steering.



**Center:**

Thinner center differential has less forward drive, can unload more under acceleration and is easier to drive on rough and slick tracks. Thicker center differential has more acceleration, increases on-power steering and less off-power steering. Thicker center differential is better on high bite/smooth tracks.

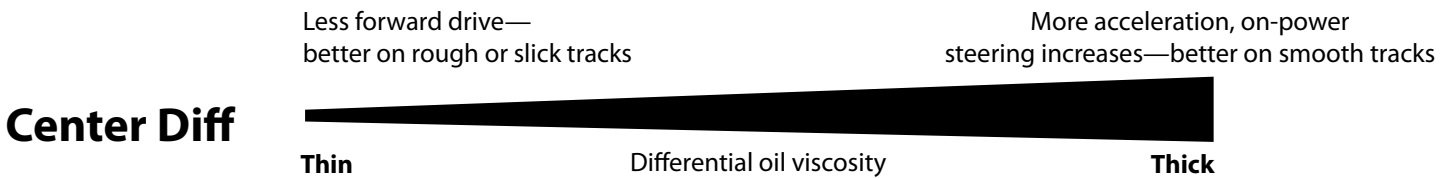

**Rear:**

Thinner rear differential has more cornering traction and increases steering in the middle of the turn. Thicker rear differential has less steering in the middle of the turn and more forward traction.

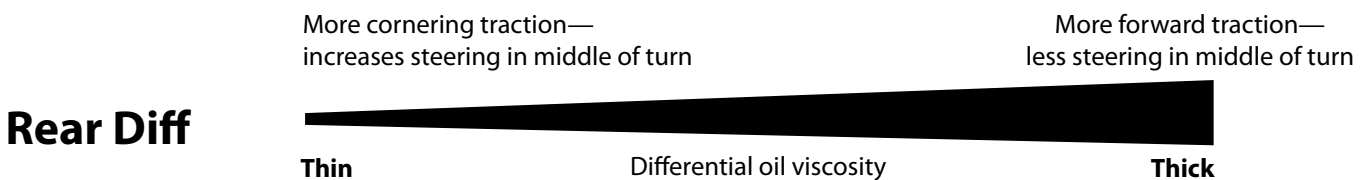

**Gearing:**

The SCTE 2.0 uses a 43-tooth ring gear with an 11-tooth pinion gearing, giving the car a drive ratio of 3.91:1. The truck comes stock with a 40-tooth MOD 1 spur gear. When gearing, it is important to consider the track, the ambient temperature, and the temperature of your electronics. As you gear up, this will make your electronics warmer and typically give you more top speed for larger, more sweeping tracks. For smaller tracks or tracks where more torque is needed, or if your electronics are too warm, you will want to gear down.

		<b>Final Drive Ratio</b>	
			<b>Spur 40</b>
<b>Pinion</b>	12		13.03:1
	13		12.03:1
	14		11.17:1
	15		10.43:1
	16		9.78:1
	17		9.20:1
	18		8.69:1
	19		8.23:1
	20		7.82:1

# TEN-SCTE 2.0 Tuning Tips

Name: _____		Date: _____	
City: _____		Event: _____	
State: _____		Track: _____	
Track Conditions: <input type="checkbox"/> Indoor <input type="checkbox"/> Tight <input type="checkbox"/> Smooth <input type="checkbox"/> Hard Packed <input type="checkbox"/> Blue Groove <input type="checkbox"/> Wet <input type="checkbox"/> Grass <input type="checkbox"/> Low Bite <input type="checkbox"/> High Bite			
<input type="checkbox"/> Outdoor <input type="checkbox"/> Open <input type="checkbox"/> Rough <input type="checkbox"/> Loose/Loamy <input type="checkbox"/> Dry <input type="checkbox"/> Dusty <input type="checkbox"/> Astro Turf <input type="checkbox"/> Med Bite <input type="checkbox"/> Other _____			

## Front Suspension

Toe: \_\_\_\_\_  
 Ride Height: \_\_\_\_\_  
 Camber: \_\_\_\_\_  
 Steering Ackerman: \_\_\_\_\_  
 Sway Bar: \_\_\_\_\_  
 Shock Type:  Bladder  Emulsion Oil: \_\_\_\_\_  
 Piston: \_\_\_\_\_  
 Spring: \_\_\_\_\_  
 Limiter/Droop: \_\_\_\_\_  
 Overall Shock Length: \_\_\_\_\_  
 Shock Location: \_\_\_\_\_  
 Bump Steer: \_\_\_\_\_  
 Camber Link: \_\_\_\_\_  
 Front Diff Fluid: \_\_\_\_\_  
 Center Diff Fluid: \_\_\_\_\_

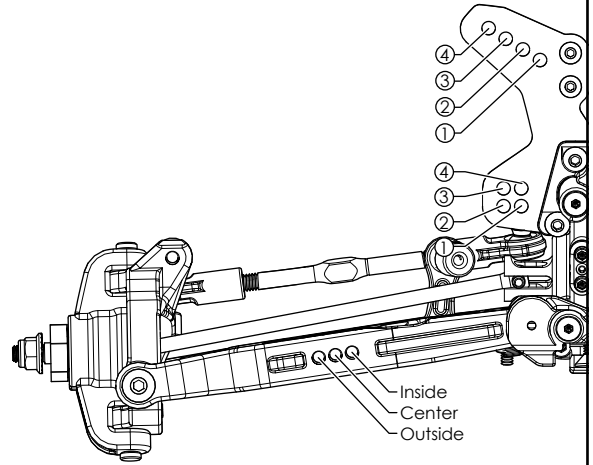

Notes: \_\_\_\_\_

\_\_\_\_\_

\_\_\_\_\_

## Rear Suspension

Toe: \_\_\_\_\_  
 Anti-Squat: \_\_\_\_\_  
 Ride Height: \_\_\_\_\_  
 Camber: \_\_\_\_\_  
 Rear Hub Spacing: \_\_\_\_\_  
 Sway Bar: \_\_\_\_\_  
 Shock Type:  Bladder  Emulsion Oil: \_\_\_\_\_  
 Piston: \_\_\_\_\_  
 Spring: \_\_\_\_\_  
 Limiter/Droop: \_\_\_\_\_  
 Camber Link: \_\_\_\_\_

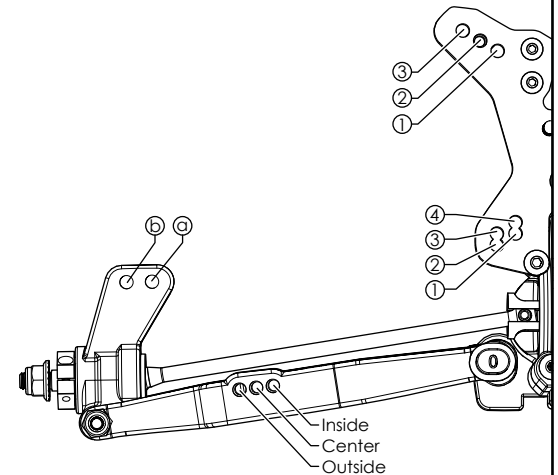

Shock Locations: \_\_\_\_\_  
 Overall Shock Length: \_\_\_\_\_  
 Rear Diff Fluid: \_\_\_\_\_  
 Battery Position: \_\_\_\_\_

## Electronics

Radio: \_\_\_\_\_  
 Servo: \_\_\_\_\_  
 ESC: \_\_\_\_\_  
 Initial Brake: \_\_\_\_\_  
 Drag Brake: \_\_\_\_\_  
 Throttle Profile: \_\_\_\_\_

Timing Advance: \_\_\_\_\_  
 Throttle/Brake Expo: \_\_\_\_\_  
 Servo Expo: \_\_\_\_\_  
 Throttle/Brake EPA: \_\_\_\_\_  
 Motor: \_\_\_\_\_  
 Pinion: \_\_\_\_\_ Spur: \_\_\_\_\_  
 Battery: \_\_\_\_\_

Weight Placement  
(Mark with "X")

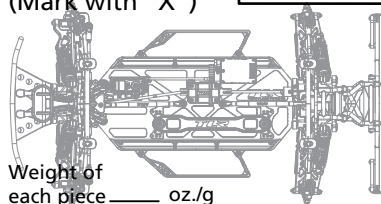

Tires	Compound	Insert	Additive
Front: _____	_____	_____	_____
Rear: _____	_____	_____	_____
Notes: _____			