

NAME: _____ DATE: _____ EVENT: _____ TRACK: _____

TRACK CONDITIONS

<input type="checkbox"/> Indoor	<input type="checkbox"/> Tight	<input type="checkbox"/> Smooth	<input type="checkbox"/> Hard Packed	<input type="checkbox"/> Blue Groove	<input type="checkbox"/> Wet	<input type="checkbox"/> Low Bite	<input type="checkbox"/> High Bite
<input type="checkbox"/> Outdoor	<input type="checkbox"/> Open	<input type="checkbox"/> Rough	<input type="checkbox"/> Loose/Loamy	<input type="checkbox"/> Dry	<input type="checkbox"/> Dusty	<input type="checkbox"/> Med Bite	<input type="checkbox"/>

COMMENTS

FRONT SUSPENSION

Ride Height	<input type="checkbox"/> 0mm
Camber	<input type="checkbox"/> 1mm
Toe	<input type="checkbox"/> 2mm
Sway Bar	<input type="checkbox"/> 0mm
	<input type="checkbox"/> 1mm
	<input type="checkbox"/> 2mm

Notes

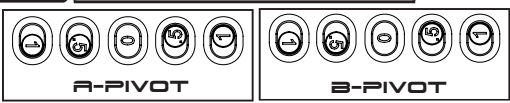
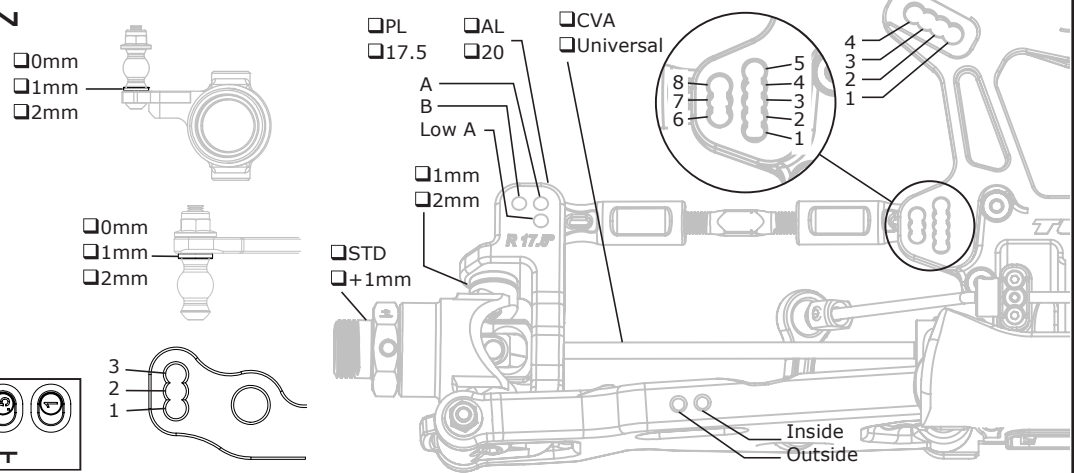

REAR SUSPENSION

Ride Height
Camber
Sway Bar

Notes

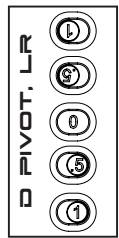
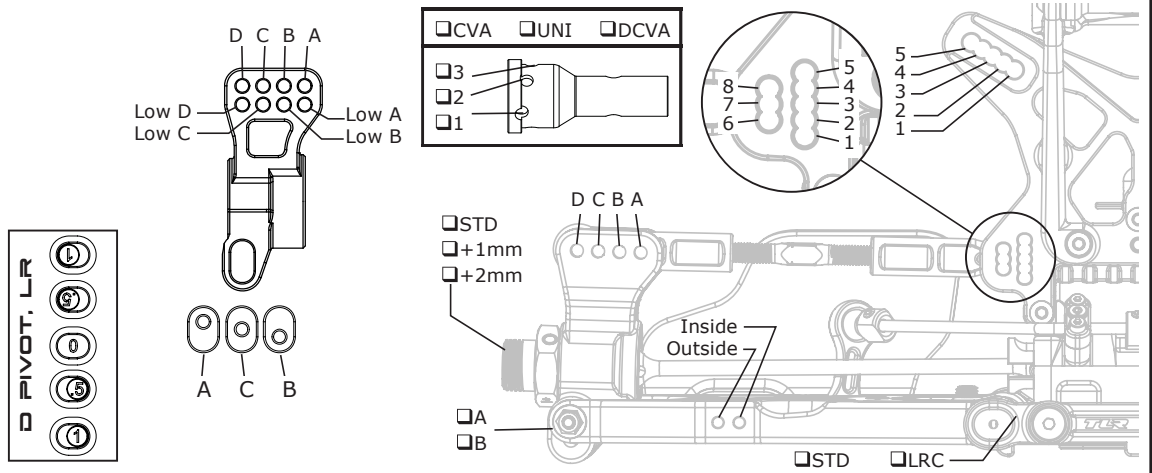

CHASSIS

DIFFERENTIALS			
	FRONT	CENTER	REAR
Fluid			
Pin	<input type="checkbox"/> AL <input type="checkbox"/> STL	<input type="checkbox"/> AL <input type="checkbox"/> STL	<input type="checkbox"/> AL <input type="checkbox"/> STL
Case	<input type="checkbox"/> STD <input type="checkbox"/> HD	<input type="checkbox"/> STD <input type="checkbox"/> HD	<input type="checkbox"/> STD <input type="checkbox"/> HD

WING
Brand
<input type="checkbox"/> Riser
<input type="checkbox"/> Wicker Bill
<input type="checkbox"/> Fwd <input type="checkbox"/> Back

ELECTRONICS
Motor
ESC
Battery
Gearing
Steering Servo
Notes

SHOCKS		
	FRONT	REAR
Shock Type	<input type="checkbox"/> Bladder <input type="checkbox"/> Re Bladder <input type="checkbox"/> Emulsion <input type="checkbox"/> Vented	<input type="checkbox"/> Bladder <input type="checkbox"/> Re Bladder <input type="checkbox"/> Emulsion <input type="checkbox"/> Vented
Shaft Diam	<input type="checkbox"/> 3.5 <input type="checkbox"/> 4.0	<input type="checkbox"/> 3.5 <input type="checkbox"/> 4.0
Piston		
Oil		
Spring		
Stroke		
Droop		

TIRES		
	FRONT	REAR
Brand		
Tread		
Compound		
Insert		
Additive		

