

<b>NAME:</b> _____		<b>DATE:</b> _____	<b>EVENT:</b> _____
<b>CITY:</b> _____		<b>STATE:</b> _____	
<b>TRACK</b>		<b>TRACK:</b> _____	
<input type="checkbox"/> Dirt <input type="checkbox"/> Carpet <input type="checkbox"/> Tight <input type="checkbox"/> Smooth <input type="checkbox"/> Hard Packed <input type="checkbox"/> Dry   Traction: <input type="checkbox"/> Low <input type="checkbox"/> Medium <input type="checkbox"/> High <input type="checkbox"/> Clay <input type="checkbox"/> Astrotruf <input type="checkbox"/> Open <input type="checkbox"/> Rough <input type="checkbox"/> Loamy <input type="checkbox"/> Wet   Notes: _____			

**FRONT SUSPENSION**

Toe: \_\_\_\_\_

Ride Height: \_\_\_\_\_

Caster Block:    17.5    20

Camber: \_\_\_\_\_

Spindle Height:    High    Low

Wheel Hex: \_\_\_\_\_

Sway Bar: \_\_\_\_\_

Piston: \_\_\_\_\_

Oil: \_\_\_\_\_ Spring: \_\_\_\_\_

Shock Type:    Bladder  
 Emulsion    Vented

Pills: A \_\_\_\_\_ B \_\_\_\_\_

Overall Shock Length: \_\_\_\_\_

Ackermann: \_\_\_\_\_

Bump Spindle: \_\_\_\_\_ Link: \_\_\_\_\_

Camber Link: \_\_\_\_\_

Shock Location: \_\_\_\_\_

Weight: \_\_\_\_\_

**DIFFERENTIALS**

Front: \_\_\_\_\_

Spring Wire Dia: \_\_\_\_\_

Qty of Spring: \_\_\_\_\_

Ramp Plate: \_\_\_\_\_

Grease: \_\_\_\_\_

Diff Fluid: \_\_\_\_\_

Center:    Std    Smart

Spring Wire Dia: \_\_\_\_\_

Qty of Spring: \_\_\_\_\_

Ramp Plate: \_\_\_\_\_

Grease: \_\_\_\_\_

Diff Fluid: \_\_\_\_\_

Rear Diff Fluid: \_\_\_\_\_

**DRIVE SHAFT**

Front:    CVA    UNI

Rear:    CVA    UNI

**ARM INSERTS**

Front:    None    Plastic    Carbon

Rear:    None    Plastic    Carbon

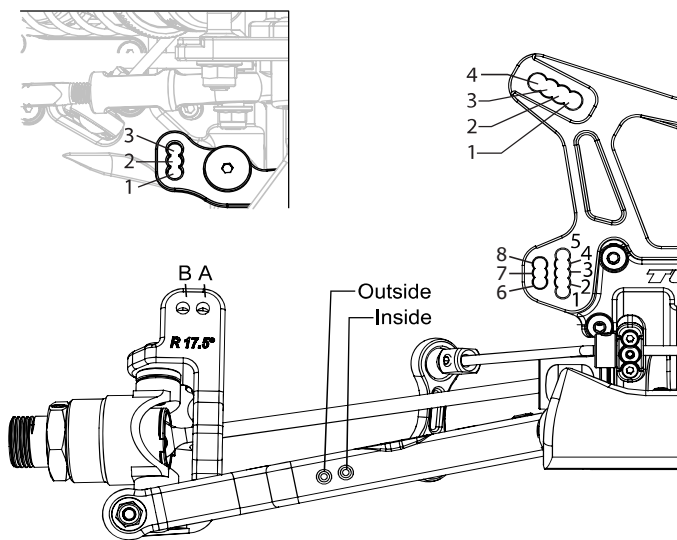

NOTES

**REAR SUSPENSION**

Toe/D Pills: \_\_\_\_\_

Anti-Squat/C Pills: \_\_\_\_\_

Ride Height: \_\_\_\_\_

Camber: \_\_\_\_\_

Rear Hubs Spacing: \_\_\_\_\_

Hub Height:    A    B    Other: \_\_\_\_\_

Wheel Hex: \_\_\_\_\_

Sway Bar: \_\_\_\_\_

Piston: \_\_\_\_\_

Oil: \_\_\_\_\_ Spring: \_\_\_\_\_

Shock Type:    Bladder  
 Emulsion    Vented

Stroke: \_\_\_\_\_

Overall Shock Length: \_\_\_\_\_

Camber Link: \_\_\_\_\_

Shock Location: \_\_\_\_\_

Weight: \_\_\_\_\_

Shocks:    FWD    Back

Shock Shaft:    3.5    4.0

**WING SETUP**

Wing Type: \_\_\_\_\_

Wickerbill:    .250    .350

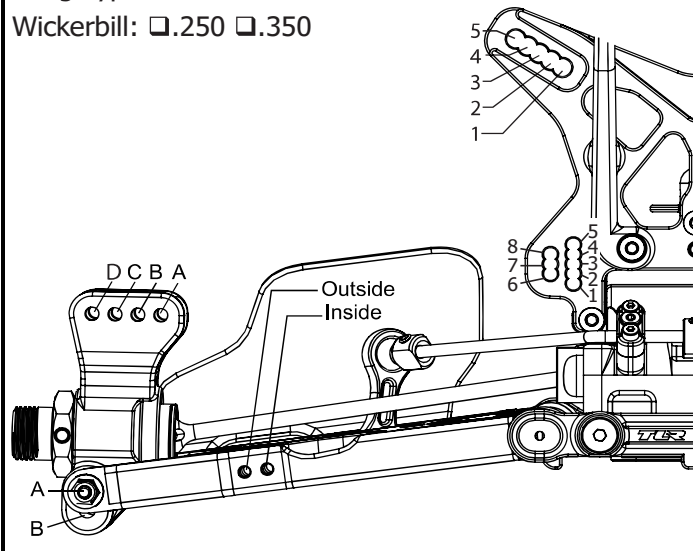

NOTES

<b>TIRES</b>	Front	Rear
Tire:	_____	_____
Compound:	_____	_____
Insert:	_____	_____
Notes:	_____	_____

**ELECTRONICS**

Radio: \_\_\_\_\_ Throttle/Brake Expo: \_\_\_\_\_

Servo: \_\_\_\_\_ Throttle/Brake EPA: \_\_\_\_\_

ESC: \_\_\_\_\_ Servo Expo: \_\_\_\_\_

Initial Brake: \_\_\_\_\_ Pinion: \_\_\_\_\_

Throttle Profile: \_\_\_\_\_ Spur: \_\_\_\_\_

Timing Advance: \_\_\_\_\_ Battery: \_\_\_\_\_