

Name: _____	Date: _____ Event: _____
City: _____ State: _____	Track: _____
Track Conditions: <input type="checkbox"/> Indoor <input type="checkbox"/> Tight <input type="checkbox"/> Smooth <input type="checkbox"/> Hard Packed <input type="checkbox"/> Blue Groove <input type="checkbox"/> Wet <input type="checkbox"/> Low Bite <input type="checkbox"/> High Bite <input type="checkbox"/> Outdoor <input type="checkbox"/> Open <input type="checkbox"/> Rough <input type="checkbox"/> Loose/Loamy <input type="checkbox"/> Dry <input type="checkbox"/> Dusty <input type="checkbox"/> Med Bite <input type="checkbox"/> Other _____	

FRONT SUSPENSION

Toe: _____

Ride Height: _____

Camber: _____

Caster: _____

Spindle Height: High Low

Wheel Hex: _____

Sway Bar: _____

Piston/Oil: _____

Shock Type: Bladder Emulsion

Spring: _____

Limiter/Droop: _____

Overall Shock Length: _____

Steering Ackerman: _____

Bump Steer: _____

Camber Link: _____

Shock Location: _____

Battery Location: Forward Aft

DIFFERENTIALS

Front: Standard Smart

Spring Wire Dia.: _____

Qty of Springs: _____

Ramp Plate: _____

Grease: _____

Diff Fluid: _____

Center: Standard Smart

Location: _____

0-Degree 4.4-Degree

Spring Wire Dia.: _____

Qty of Springs: _____

Ramp Plate: _____

Grease: _____

Diff Fluid: _____

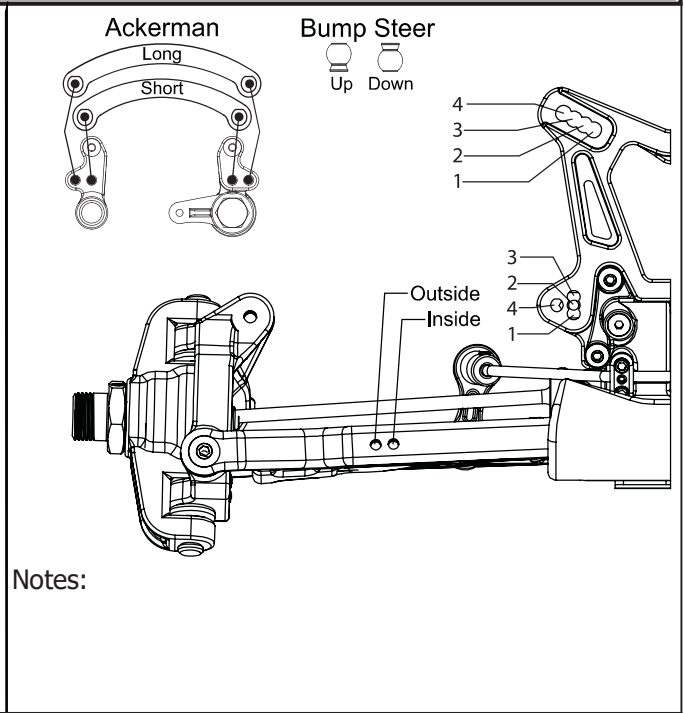

REAR SUSPENSION

Roll Center: HRC LRC

Toe: _____

Anti-Squat: _____

Ride Height: _____

Camber: _____

Rear Hub Spacing: _____

Wheel Hex: _____

Sway Bar: _____

Piston/Oil: _____

Shock Type: Bladder Emulsion

Spring: _____

Limiter/Droop: _____

Overall Shock Length: _____

Camber Link: _____

Shock Position: _____

Rear Diff Fluid: _____

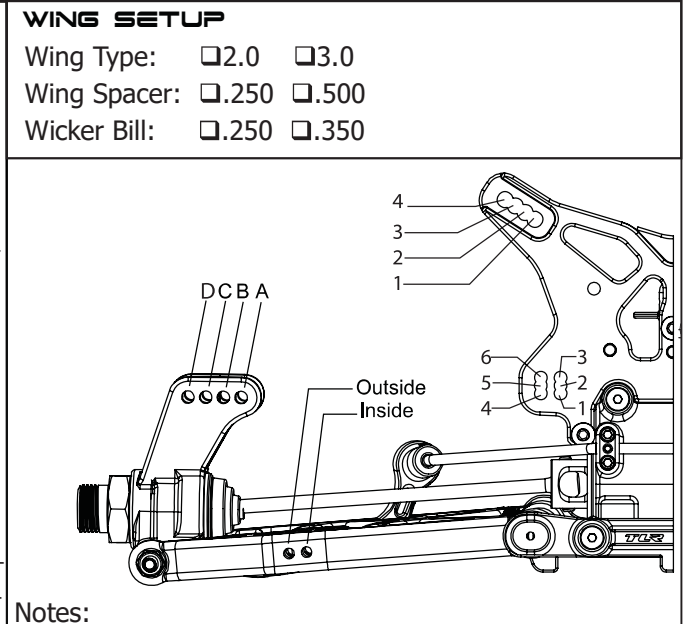

ELECTRONICS

Radio: _____

Servo: _____

ESC: _____

Initial Brake: _____

Drag Brake: _____

Throttle Profile: _____

Timing Advance: _____

Throttle/Brake Expo: _____

Throttle/Brake EPA: _____

Servo Expo: _____

Motor: _____

Pinion: _____

Spur: _____

Battery: _____

CLUTCH Clutch Shoes and Springs Info

TIRES

Type	Compound	Insert
Front: _____	_____	_____
Rear: _____	_____	_____

Notes: _____