

Name: _____ Date: _____ Event: _____
 City: _____ State: _____ Track: _____



Track Dirt Carpet Tight Smooth Hard Packed Dry Grip Level: Low Medium High
 Conditions: Clay Astro Turf Open Rough Loamy Wet Tread Level: Pin Ghost Pin Slicks

Front Suspension

Toe: _____ Camber: _____
 Ride Height: _____ Caster Block: 0° 5°
 Kick Shim(s): 2mm 1mm Wedge(20°) Other: _____
 VLA Setting: Short Arm Long Arm
 Front Pivot: Alum Composite Brass _____
 Pivot Height: SLRC LRC MRC HRC
 Piston: _____ Oil: _____
 Limiters: Internal: _____ External: _____ Stroke: _____
 Shock Eyelet: Std. +2 Shock Location: _____
 Spring: _____ Sway Bar: _____
 Spindle Steering Arm: 4 5 6 _____
 Spindle Ball Stud: Standard Low Spacers: _____
 Draglink Ball Stud: Standard Low Spacers: _____
 Axle Spacing: 0 +.5mm +1mm
 Trail: 2mm 3mm 4mm
 Camber Link, Inner: 1 2 3 Outer: A B
 Tower: Stiffezel Carbon Carbon +2mm _____
 Mud Guard: Soft Standard Stiffezel
 Front Wheels: Standard Stiffezel
 Front Wing: Low High Narrow High Wide

Stiffezel Parts:
 Front Arm Rear Arm
 Chassis Brace/Waterfall

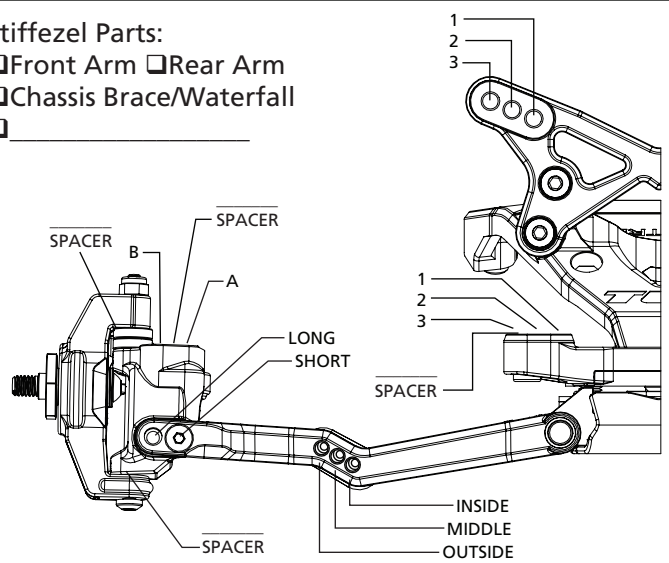

Notes: _____

Rear Suspension

Configuration: Laydown Standup
 Diff. Height: 0 +1 +1.75 + 2.5 +3.5
 Axle Height: 0 +3 _____
 Toe Plate: LRC LRC -2° HRC HRC -2°
 Toe Inserts: 2.5 3.0 3.5 4.0 Arrow: In Out
 Anti-Squat Inserts: 0 0.5 1 1.5 2 2.5 3
 Ride Height: _____ Camber: _____
 Hub Spacing: _____ Fr _____ Rr Hex Width: _____
 Piston: _____ Oil: _____
 Spring: _____ Sway Bar: _____
 Limiters: Internal: _____ External: _____ Stroke: _____
 Shock Eyelet: Std. +2 Shock Location: _____
 Shock Mounting: Front Rear
 Tower: Stiffezel Carbon Carbon +2mm _____
 Camber Block Spacer: 1mm ↓ 0mm 1mm ↑
 Camber Link, Inner: 1 2 3
 Camber Link, Outer: A B C D E
 Battery Position: 1 2 3 4 5 _____
 Wing/Wickerbill: _____
 Wing Angle: 0° 2° 4°
 Diff Type: Ball Gear Setting: _____
 Driveshaft Length: CVA Universal Length: _____
 Direct Drive Slipper Pads: Torque (yel) Drive (org)

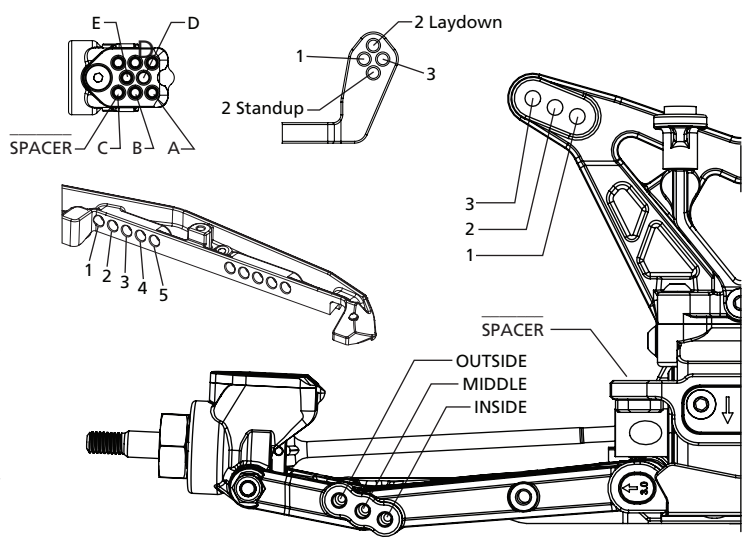

Electronics

Radio: _____ Timing Advance: _____
 Servo: _____ Steering Expo: _____
 ESC: _____ Throttle/Brake EPA: _____
 Initial Brake: _____ Motor: _____
 Drag Brake: _____ Pinion: _____ Spur: _____
 Throttle Profile: _____ Battery: _____
 Battery Weight: _____

Tires

	Front	Rear
Thread:	_____	_____
Compound:	_____	_____
Insert:	_____	_____
Sauce:	_____	_____

Notes: _____

Chassis

Electronics Plate Brass, 36g Carbon
 Battery Plate 19g 26g 37g _____
 Rear Ballast 16g 25g
 Anti-Squat Block Brass, 22g Aluminum
 Total Weight: _____
 FR: _____ % RR: _____ %