

Name: Ryan Harris Date: 2021 Event: Outdoors Track:

**Track Conditions**

Indoor  Clay  Carpet  Tight  Smooth  Hard Packed  Blue Groove  Wet Bite:  Low  Med  High Other: Damp, Loamy  
 Outdoor  Dirt  Astro  Open  Rough  Loose/Loamy  Dry  Dusty Tread:  Pin  Ghost  Slicks

**Front Suspension**

Ride Height	22	mm
Camber	-1	°
Toe	0	°
Sway Bar	None	mm
Notes:		

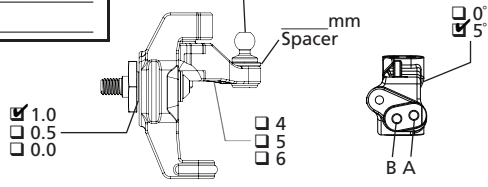
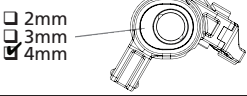
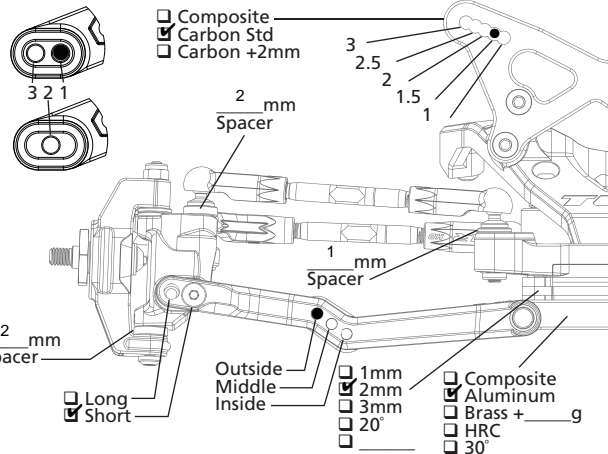
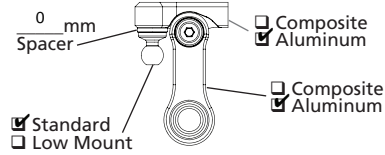

**Rear Suspension**

Ride Height	22	mm
Camber	-1	°
Sway Bar	None	mm
Notes:	Stand up conversion installed in a 22 5.0 Elite. Battery brace removed completely, taped battery in +10mm from waterfall. If using TLR pistons, use 32.5F 27.5R oil.	

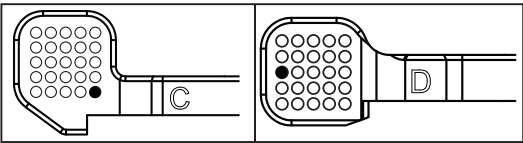
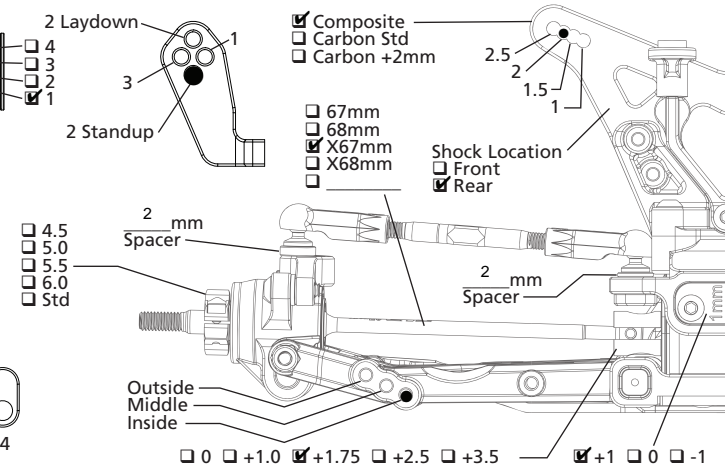
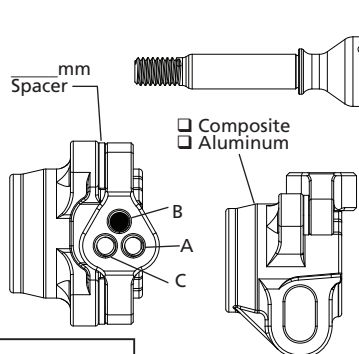

**Chassis**

Drive Train	
Diff Type	<input checked="" type="checkbox"/> Ball Diff <input type="checkbox"/> Gear Diff
Setting/Fluid	Normal
Internal Gears	<input type="checkbox"/> Steel <input type="checkbox"/> Composite
Planet Gears	<input type="checkbox"/> 2 <input type="checkbox"/> 4
Slipper	<input checked="" type="checkbox"/> Slipper <input type="checkbox"/> Direct Drive
Slipper Pads	<input checked="" type="checkbox"/> Torque/Yellow <input type="checkbox"/> Drive/Orange

Aerodynamics	
Body	TLR
Fr Wing	None
Rr Wing	Rawspeed
Wicker	Normal
Angle	+2mm °
Notes	Cut notches for shocks

Tires		
	Front	Rear
Brand	Rawspeed	Rawspeed
Tread	Super Mini	Super Mini
Compound	Soft	Super Soft
Insert	Open	Open
Sauce	None	None
Wheel	<input checked="" type="checkbox"/> Standard <input type="checkbox"/> Stiffezel	
Notes		

**Shocks**

	Front	Rear
Shock Caps	Domed	Domed
Oil	22.5 TLR	17.5 TLR
Piston	VRP GC 1.6 <input type="checkbox"/> Thin	VRP GC 1.7 <input type="checkbox"/> Thin
Limiters, Int	0 mm	0 mm
Shaft Dia	<input checked="" type="checkbox"/> 3.0mm <input type="checkbox"/> 3.5mm	<input checked="" type="checkbox"/> 3.0mm <input type="checkbox"/> 3.5mm
Limiters, Ext	0 mm	0 mm
Stroke	24 mm	30.5 mm
Eyelet	<input checked="" type="checkbox"/> Std <input type="checkbox"/> +2mm	<input checked="" type="checkbox"/> Std <input type="checkbox"/> +2mm
Spring	TLR Green	TLR White
Spring Cup	<input type="checkbox"/> Low <input checked="" type="checkbox"/> Mid <input type="checkbox"/> High	<input checked="" type="checkbox"/> Low <input type="checkbox"/> Mid <input type="checkbox"/> High

Electronics			
Radio	M17	ESC	Hobbywing XR10 G2
Servo	S6245 w/ mount	Thro Prof	8k
Battery	Trinity 4300 White Carbon	Timing Adv	none
Battery Wt	g	Initial Brake	100
Motor	Xfactor 17.5	Drag Brake	none
Gearing	72 / 27	Thr/Bra EPA	95 / 80

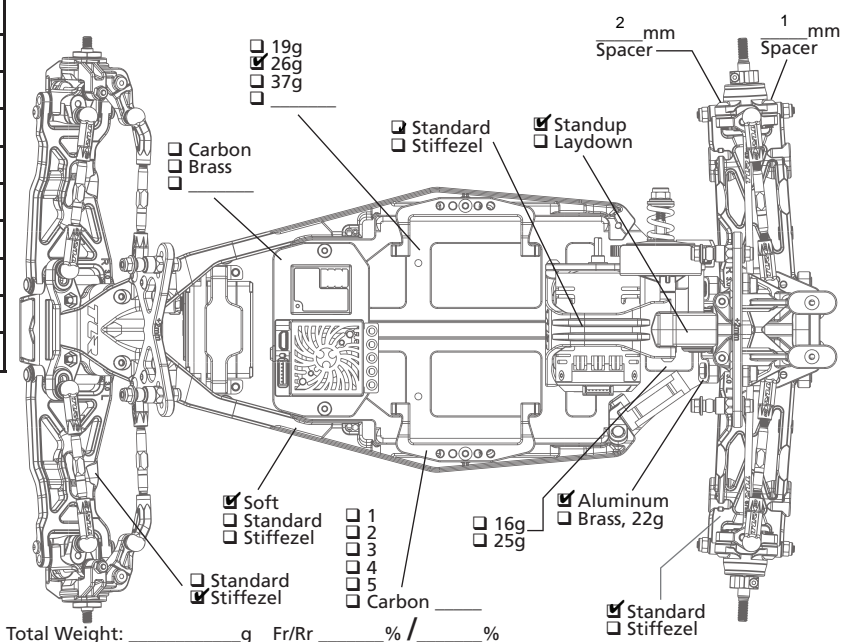

Total Weight: \_\_\_\_\_ g Fr/Rr \_\_\_\_\_ % / \_\_\_\_\_ %