

Track Conditions

<input checked="" type="checkbox"/> Indoor	<input checked="" type="checkbox"/> Clay	<input type="checkbox"/> Carpet	<input checked="" type="checkbox"/> Tight	<input checked="" type="checkbox"/> Smooth	<input checked="" type="checkbox"/> Hard Packed	<input type="checkbox"/> Blue Groove	<input type="checkbox"/> Wet	Bite: <input type="checkbox"/> Low <input type="checkbox"/> Med <input checked="" type="checkbox"/> High	Other: Sealed Dirt Surface
<input type="checkbox"/> Outdoor	<input type="checkbox"/> Dirt	<input type="checkbox"/> Astro	<input type="checkbox"/> Open	<input type="checkbox"/> Rough	<input type="checkbox"/> Loose/Loamy	<input type="checkbox"/> Dry	<input type="checkbox"/> Dusty	Tread: <input type="checkbox"/> Pin <input type="checkbox"/> Ghost <input checked="" type="checkbox"/> Slicks	Layout was new for weekend

Front Suspension

Ride Height	17	mm
Camber	-1.5	°
Toe	0	°
Sway Bar	None	mm

Notes: Entire front end is setup with the 0 Deg caster block in mind.

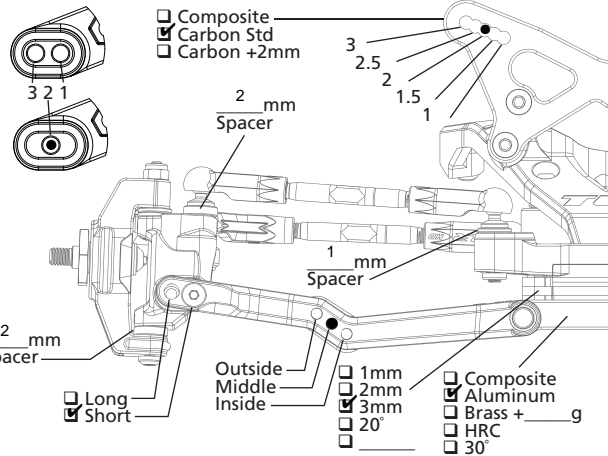
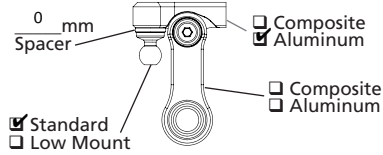

- 2mm
- 3mm
- 4mm
- 1.0
- 0.5
- 0.0
- 4
- 5
- 6
- 0°
- 5°

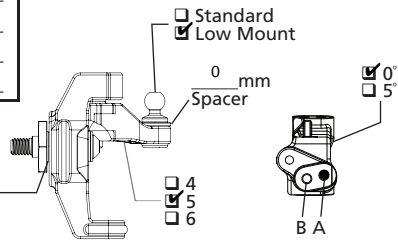

Rear Suspension

Ride Height	17	mm
Camber	-1.5	°
Sway Bar	None	mm

Notes: 2wd rear arm, wide pivot.
Rear shock on lower outside hole and dropped oil by 5wt to get correct feel.

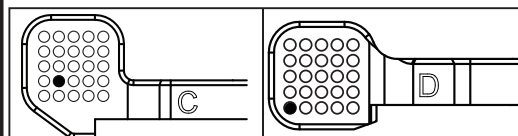
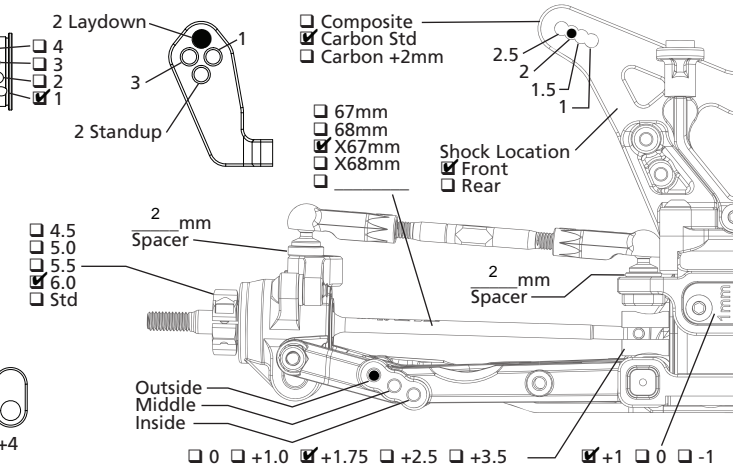
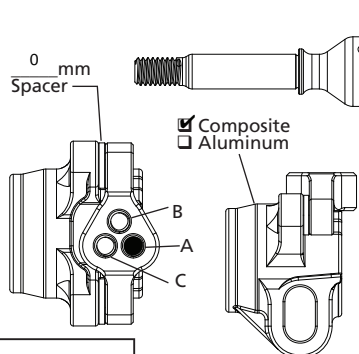

Chassis

Drive Train	
Diff Type	<input checked="" type="checkbox"/> Ball Diff <input type="checkbox"/> Gear Diff
Setting/Fluid	Tight
Internal Gears	<input type="checkbox"/> Steel <input type="checkbox"/> Composite
Planet Gears	<input type="checkbox"/> 2 <input type="checkbox"/> 4
Slipper	<input checked="" type="checkbox"/> Slipper <input type="checkbox"/> Direct Drive
Slipper Pads	<input checked="" type="checkbox"/> Torque/Yellow <input type="checkbox"/> Drive/Orange

Aerodynamics	
Body	Rawspeed RS-2
Fr Wing	TLR High narrow
Rr Wing	Rawspeed
Wicker	Low
Angle	+2mm
Notes	

Tires		
	Front	Rear
Brand	Rawspeed	Rawspeed
Tread	Slick	Slick
Compound	Clay (White)	Clay (White)
Insert	Rawspeed	Rawspeed V-Cut
Sauce	TDK 2.0	TDK 2.0
Wheel	<input checked="" type="checkbox"/> Standard <input type="checkbox"/> Stiffezel	TLR
Notes	Warmers for 5 min	Warmers for 5 min

Shocks

	Front	Rear
Shock Caps	Domed	Domed
Oil	25wt TLR	17.5wt TLR
Piston	VRP GC 1.6 <input type="checkbox"/> Thin	VRP GC 1.7 <input type="checkbox"/> Thin
Limiters, Int	0 mm	0 mm
Shaft Dia	<input checked="" type="checkbox"/> 3.0mm <input type="checkbox"/> 3.5mm	<input checked="" type="checkbox"/> 3.0mm <input type="checkbox"/> 3.5mm
Limiters, Ext	1 mm	0 mm
Stroke	24 mm	30.5 mm
Eyelet	<input checked="" type="checkbox"/> Std <input type="checkbox"/> +2mm	<input checked="" type="checkbox"/> Std <input type="checkbox"/> +2mm
Spring	Kyosho White X Spring	Kyosho White X Spring
Spring Cup	<input type="checkbox"/> Low <input checked="" type="checkbox"/> Mid <input type="checkbox"/> High	<input checked="" type="checkbox"/> Low <input type="checkbox"/> Mid <input type="checkbox"/> High

Electronics			
Radio	M17	ESC	Hobbywing XR10 G2
Servo	S6245 w/ mount	Thro Prof	4k
Battery	Trinity 4300 White Carbon	Timing Adv	0
Battery Wt	g	Initial Brake	100
Motor	Xfactor Cert 17.5	Drag Brake	0
Gearing	72 / 25	Thr/Bra EPA	100 / 85

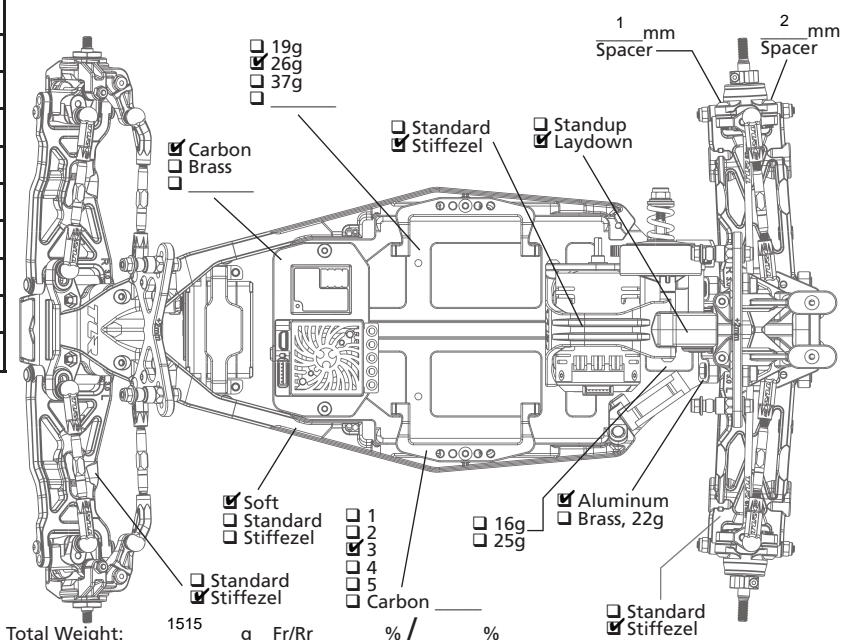

Total Weight: 1515 g Fr/Rr % / %