

Name: _____	Date: _____ Event: _____
City: _____ State: _____	Track: _____
Track Conditions: <input type="checkbox"/> Indoor <input type="checkbox"/> Tight <input type="checkbox"/> Smooth <input type="checkbox"/> Hard Packed <input type="checkbox"/> Blue Groove <input type="checkbox"/> Wet <input type="checkbox"/> Grass <input type="checkbox"/> Low Bite <input type="checkbox"/> High Bite <input type="checkbox"/> Outdoor <input type="checkbox"/> Open <input type="checkbox"/> Rough <input type="checkbox"/> Loose/Loamy <input type="checkbox"/> Dry <input type="checkbox"/> Dusty <input type="checkbox"/> Astro Turf <input type="checkbox"/> Med Bite <input type="checkbox"/> Other _____	

Front Suspension

Toe: _____
 Ride Height: _____ Camber: _____
 Caster: 0° 5°
 Kick Angle: 20° 25° 30°
 VLA Setting: Short Arm Long Arm
 Oil: _____
 Piston: _____
 Spring: Standard Low Freq. Color: _____
 Front Pivot: Aluminum Plastic HRC
 Kick Shim: Brass Plastic
 Shock Limiters: _____ Stroke: _____
 Shock Location: _____
 Steering Type: Slide Rack Bell Cranks
 Spindle Ball Stud: Standard Low Mount
 Bumper Steer Spacers: _____
 Ackerman Ball Stud: Standard Low Mount
 Ackerman Spacers: _____
 Ackerman Arm: #1 #2 #3 _____
 Trail: 2mm 3mm 4mm
 Camber Link: _____

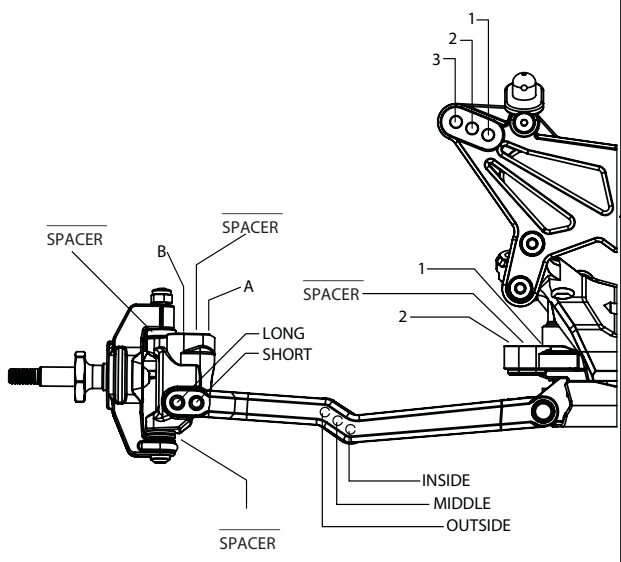

Notes: _____

Rear Suspension

Transmission Type: 3-Gear 4-Gear
 Toe Inserts: 0.5° 1° 1.5° 2° 2.5° 3° 3.5° 4°
 Anti-Squat Inserts: 0° 0.5° 1° 1.5° 2° 2.5° 3°
 Roll Center: Low Roll Center (LRC) High Roll Center (HRC)
 Ride Height: _____ Camber: _____
 Rear Hub Spacing: _____
 Hex Width: _____
 Sway Bar: _____
 Oil: _____
 Piston: _____
 Spring: Standard Low Freq. Color: _____
 Shock Limiters: _____ Stroke: _____
 Shock Location: _____
 Inner Link Spacer: -1mm 0mm +1mm
 Camber Link: _____
 Body/Spoiler: _____
 Battery Position: _____
 Diff Type: Ball Gear Setting: _____

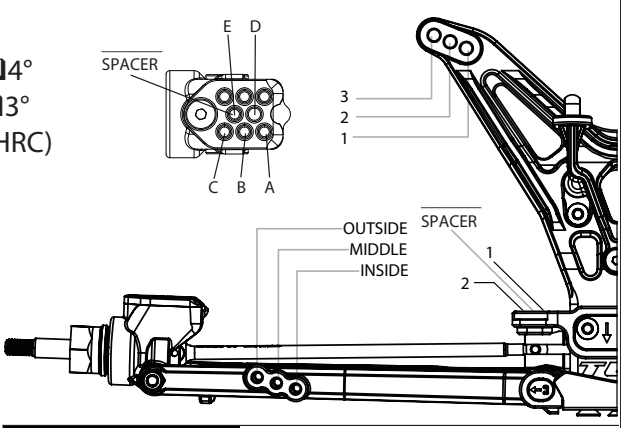

Electronics

Radio: _____ Timing Advance: _____
 Servo: _____ Throttle/Brake Expo: _____
 ESC: _____ Servo Expo: _____
 Initial Brake: _____ Throttle/Brake EPA: _____
 Drag Brake: _____ Motor: _____
 Throttle Profile: _____ Pinion: _____ Spur: _____
 Battery: _____

Weight Placement (Mark with "X")

Weight of each piece _____ oz./g

Tires:	Compound	Insert	Additive
Front: _____	_____	_____	_____
Rear: _____	_____	_____	_____
Notes: _____	_____		