

NAME: \_\_\_\_\_

DATE: \_\_\_\_\_ EVENT: \_\_\_\_\_



CITY: \_\_\_\_\_ STATE: \_\_\_\_\_

TRACK: \_\_\_\_\_

- TRACK CONDITIONS
- |                                  |                                |                                 |                                      |                                      |                                |                                    |                                   |                                      |
|----------------------------------|--------------------------------|---------------------------------|--------------------------------------|--------------------------------------|--------------------------------|------------------------------------|-----------------------------------|--------------------------------------|
| <input type="checkbox"/> Indoor  | <input type="checkbox"/> Tight | <input type="checkbox"/> Smooth | <input type="checkbox"/> Hard Packed | <input type="checkbox"/> Blue Groove | <input type="checkbox"/> Wet   | <input type="checkbox"/> Grass     | <input type="checkbox"/> Low Bite | <input type="checkbox"/> High Bite   |
| <input type="checkbox"/> Outdoor | <input type="checkbox"/> Open  | <input type="checkbox"/> Rough  | <input type="checkbox"/> Loose/Loamy | <input type="checkbox"/> Dry         | <input type="checkbox"/> Dusty | <input type="checkbox"/> AstroTurf | <input type="checkbox"/> Med Bite | <input type="checkbox"/> Other _____ |

**FRONT SUSPENSION**

Toe: \_\_\_\_\_  
 Ride Height: \_\_\_\_\_ Camber: \_\_\_\_\_  
 Caster: 0° 5°  
 Kick Angle: 20° 25° 30°  
 VLA Setting: Short Arm Long Arm  
 Front Pivot: Aluminum Plastic HRC HRC Aluminum  
 Kick Shim: Brass Plastic  
 Oil: \_\_\_\_\_ Piston: \_\_\_\_\_  
 Spring: Standard Low Freq. Color: \_\_\_\_\_  
 Sway Bar: 0.8mm 1.0mm 1.2mm  \_\_\_\_\_  
 Shock Limiters: \_\_\_\_\_ Stroke: \_\_\_\_\_  
 Shock Locations: \_\_\_\_\_  
 Spindle Ball Stud: Standard Low Mount  
 Bump Steer Spacers: \_\_\_\_\_  
 Ackerman Ball Stud: Standard Low Mount  
 Ackerman Spacers: \_\_\_\_\_  
 Ackerman Arm: #1 #2 #3  \_\_\_\_\_  
 Axle Spacing: 0mm +0.5mm +1mm  
 Trail: 2mm 3mm 4mm  
 Camber Link: \_\_\_\_\_

- Stiffezel Parts:  
Front Arm Rear Arm  
Chassis Brace  
Front Camber Block  
 \_\_\_\_\_

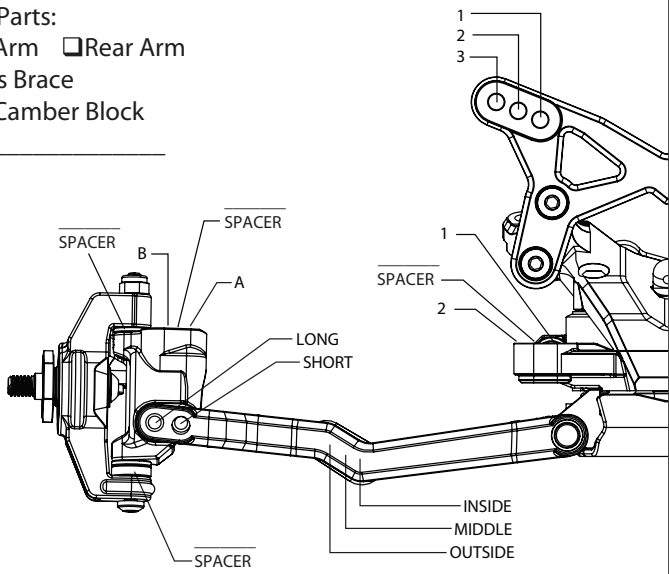

NOTES

**REAR SUSPENSION**

Configuration: Laydown Stand-Up  
 LD Diff. Height: Standard +3.5mm  
 Transmission Type: 3-Gear 4-Gear  
 Toe Inserts: 0.5° 1° 1.5° 2° 2.5° 3° 3.5° 4°  
 Anti-Squat Inserts: 0.5° 1° 1.5° 2° 2.5° 3°  
 Inner Roll Center: LRC HRC  
 Ride Height: \_\_\_\_\_ Camber: \_\_\_\_\_  
 Rear Hub Spacing: \_\_\_\_\_  
 Rear Axle Height: Standard +3mm  
 Hex Width: \_\_\_\_\_  
 Sway Bar: 1.0mm 1.2mm 1.4mm  \_\_\_\_\_  
 Oil: \_\_\_\_\_ Piston: \_\_\_\_\_  
 Spring: Standard Low Freq. Color: \_\_\_\_\_  
 Shock Limiters: \_\_\_\_\_ Stroke: \_\_\_\_\_  
 Shock Locations: \_\_\_\_\_  
 Shock Mounting: Front Rear  
 Inner Link Spacer: -1mm 0mm +1mm  
 Camber Link: \_\_\_\_\_  
 Wing/Wickerbill: \_\_\_\_\_  
 Wing Angle: 0° 2° 4°  
 Battery Position: \_\_\_\_\_  
 Diff Type: Ball Gear Setting: \_\_\_\_\_  
 Driveshaft Length: CVA Universal Length: \_\_\_\_\_

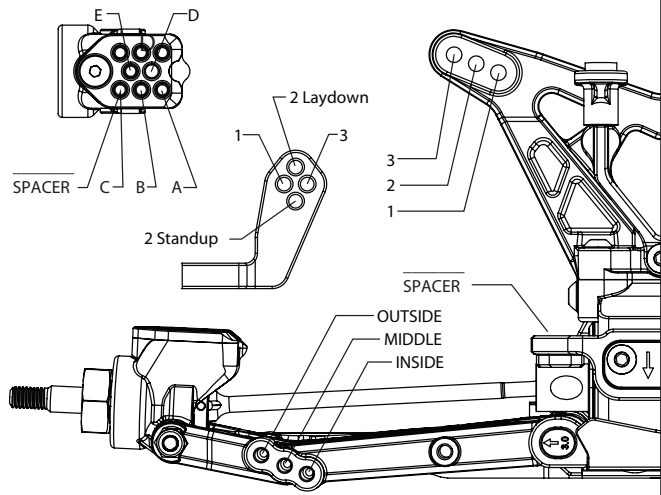

NOTES

**ELECTRONICS**

Radio: \_\_\_\_\_ Timing Advance: \_\_\_\_\_  
 Servo: \_\_\_\_\_ Throttle/Brake Expo: \_\_\_\_\_  
 ESC: \_\_\_\_\_ Servo Expo: \_\_\_\_\_  
 Initial Brake: \_\_\_\_\_ Throttle/Brake EPA: \_\_\_\_\_  
 Drag Brake: \_\_\_\_\_ Motor: \_\_\_\_\_  
 Pinion: \_\_\_\_\_ Spur: \_\_\_\_\_  
 Battery: \_\_\_\_\_

**CHASSIS**

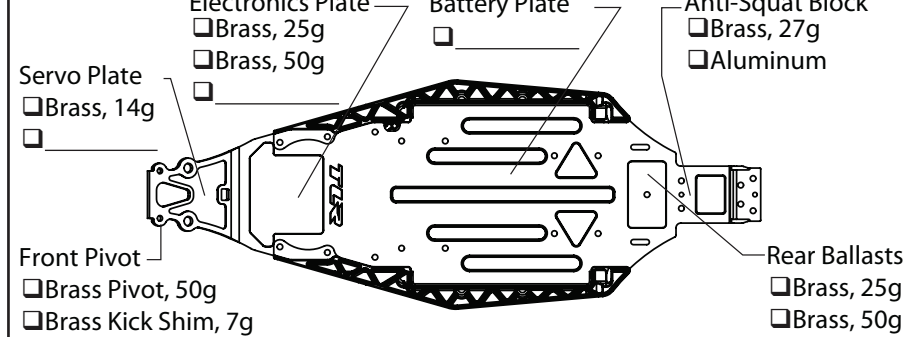

<b>TIRES</b>	<b>FRONT</b>	<b>REAR</b>
Tire: _____	_____	_____
Compound: _____	_____	_____
Insert: _____	_____	_____
Additive: _____	_____	_____

NOTES