

Driver _____ Date _____ Air temp _____ Humidity _____

Track _____ Track temp _____ Track Condition _____

FRONT

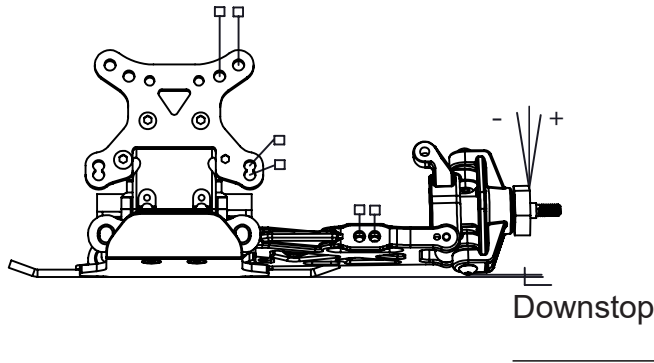

Camber

L _____

R _____

Ride height _____ mm

Front Tire

Type _____

Notes _____

Gear Diff

Oil _____

Oil Shock

Preload Front _____

Rear _____

Oil Shock length Front _____ Rear _____

Piston Front _____ Rear _____

Spring Front _____ Rear _____

REAR

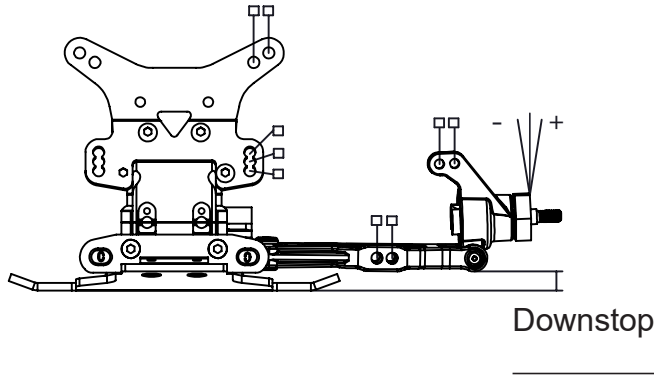

Camber

L _____

R _____

Ride height _____ mm

Rear Tire

Type _____

Notes _____

Gear Diff

Oil _____

Toe Angle (Front)

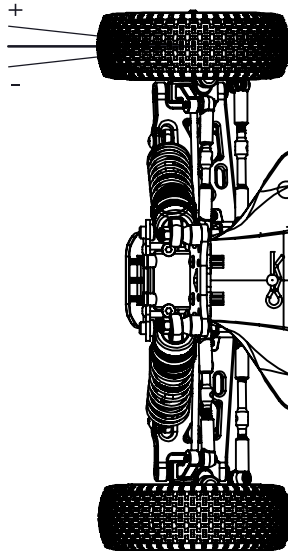

Notes (Front)

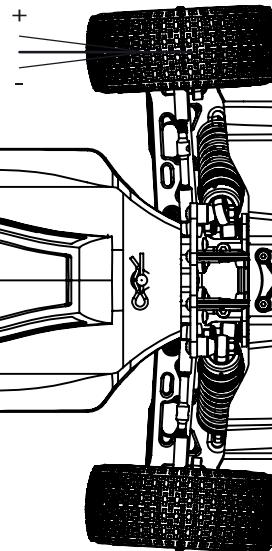

Toe Angle (Rear)

Notes (Rear)

Motor: _____ Spur gear: _____ Pinion gear: _____ Battery: _____ Body: _____

Servo: _____ Wing: _____ Front Tire Insert: _____ Rear Tire Insert: _____

Front Anti Roll Bar: _____ Rear Anti Roll Bar: _____

Memo: _____