

Name
秋元 宏太

Date
2010/2/27

Truck
谷田部アリーナ

Event
Y.I.O-GP向け

Front Suspension

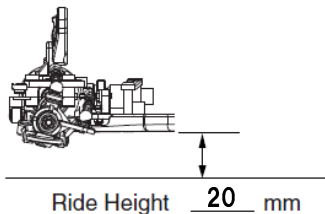
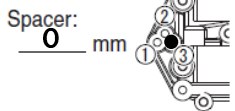
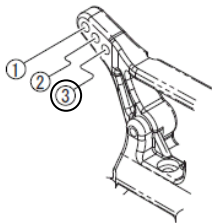

Camber Angle: -1 °
Toe Angle: 0 °
Sway Bar: 1.0mm

Front Diff:
 Rigid
 Oneway
 Differential, Setting: リヤと同じ

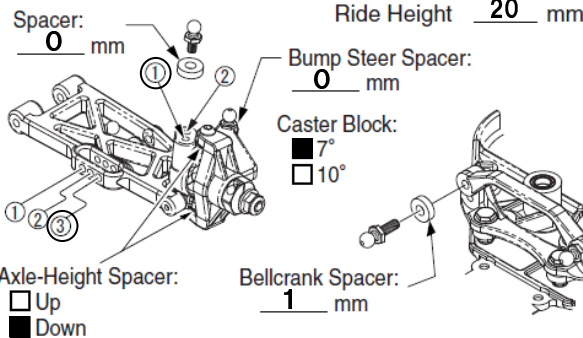
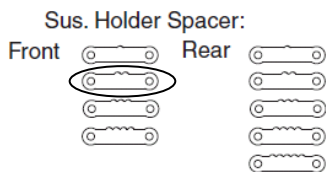

Shock Piston: 2C
Shock Oil: # 35 ※1
Shock Spring: # ホワイト ※1

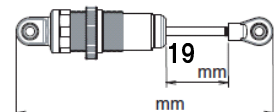

Rear Suspension

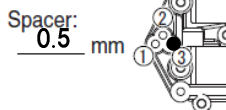
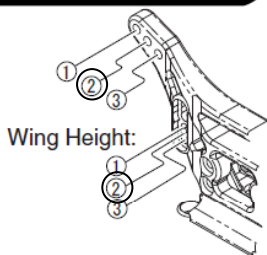

Camber Angle: 1 °
Sway Bar: 1.2mm

Sus. Holder(RF):
 Standard
 LAW36
 IN OUT B

Sus. Holder(RR):
 Standard
 LAW37
 IN OUT F

Ride Height 20.5 mm

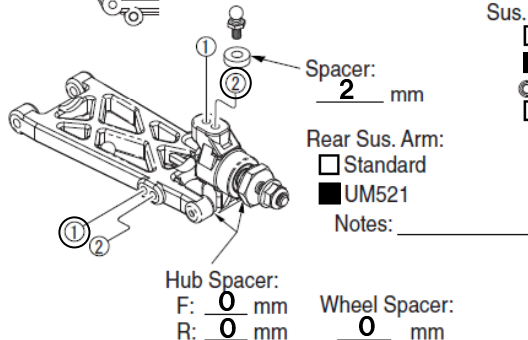
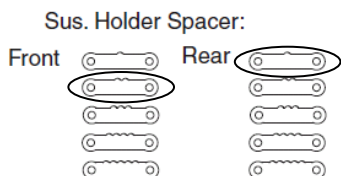

Shock Piston: 2B
Shock Oil: # 32.5 ※1
Shock Spring: # ホワイト ※1

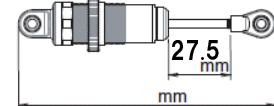

Tire

Compound:

Front Tire: Bobcat Clay
Rear Tire: Switch2.0 Clay
Front Inserts: Normal
Rear Inserts: Normal

Others

Motor: VORTEX 7.5T
Pinion/Spur: 20 / 78
Wing: Step-M
Wing Angle: 0° 7°
 4°

Slipper Type:

Direct
 Separates

Slipper Sheet(F-R):

Red-White
 Red-Red
 White-White

Truck Condition

Smooth Dry
 Bumpy Wet
 Low Truaction Dusty
 Med. Truaction Indoor
 High Truaction Outdoor

Spring Rate

#50	Black	#68	Blue
#55	Orange	#70	Silver
#60	Orange Yellow	#72	Cobalt Blue
#65	Yellow	#75	Light Green

Gear Ratio

Secondary Gear Ratio 2.5 (16:40)

	16	17	18	19	20	21	22	23	24	25
76		11.18	10.56	10.00	9.50	9.05	8.64	8.26	7.92	7.60
78	12.19	11.47	10.83	10.26	9.75	9.29	8.86	8.48	8.13	7.80

Shock Piston

Soft ← → Hard

3-A 2-B 3-B 2-C

Sway Bar

1.0	Nickel
1.1	Gold
1.2	Silver
1.3	Copper
1.4	Black
1.5	Golden
1.6	Chromium

ESC&Battery

ESC: KO BMC
ESC Setting: _____

Battry: ORION 4500 Lipo

Battry Position:

Front
 Rear

Comments

※1:オイル/スプリング共にX-GEAR製を使用。