

Name \_\_\_\_\_

Date \_\_\_\_\_

Track / City \_\_\_\_\_

Event \_\_\_\_\_

### Front Suspension

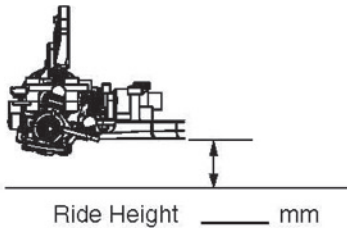
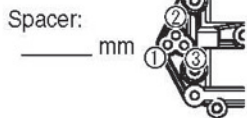
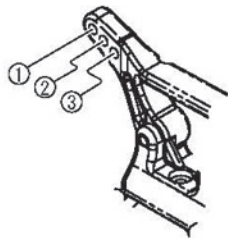

Camber Angle: \_\_\_\_\_ °

Toe Angle: \_\_\_\_\_ °

Sway Bar: \_\_\_\_\_

Front Diff:

- Rigid  
 Oneway  
 Differential, Setting: \_\_\_\_\_

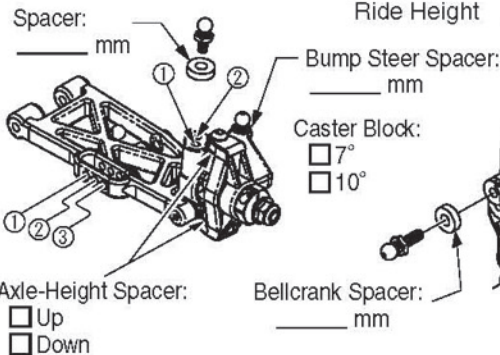
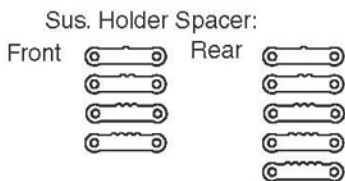

Shock Piston: \_\_\_\_\_  
 Shock Oil: # \_\_\_\_\_  
 Shock Spring: # \_\_\_\_\_

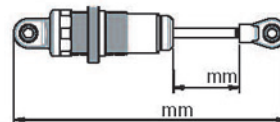

### Rear Suspension

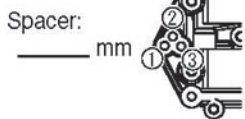
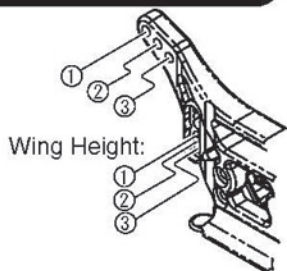

Camber Angle: \_\_\_\_\_ °

Sway Bar: \_\_\_\_\_

Sus. Holder(RF):

- Standard  
 LAW36  
 IN  OUT \_\_\_\_\_

Sus. Holder(RR):

- Standard  
 LAW37  
 IN  OUT \_\_\_\_\_

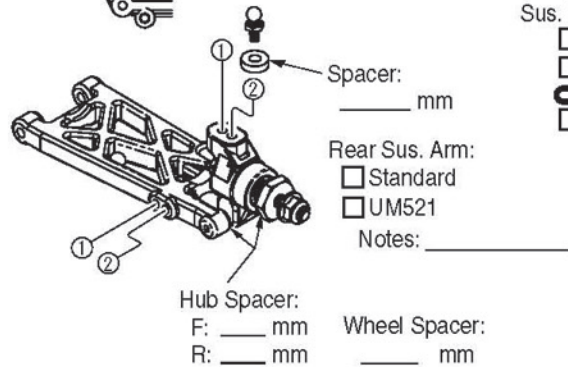
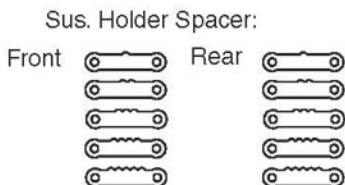
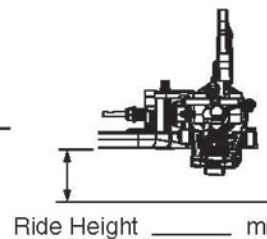

Shock Piston: \_\_\_\_\_  
 Shock Oil: # \_\_\_\_\_  
 Shock Spring: # \_\_\_\_\_

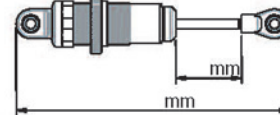

### Tire

Front Tire: \_\_\_\_\_  
 Rear Tire: \_\_\_\_\_  
 Front Inserts: \_\_\_\_\_  
 Rear Inserts: \_\_\_\_\_

Compound: \_\_\_\_\_

### Others

Motor: \_\_\_\_\_  
 Pinion/Spur: \_\_\_\_\_ / \_\_\_\_\_  
 Wing: \_\_\_\_\_  
 Wing Angle:  0°  7°  
 4°

Slipper Type:

- Direct  
 Separates

Slipper Sheet(F-R):

- Red-White  
 Red-Red  
 White-White

### Track Condition

- Smooth  Dry  
 Bumpy  Wet  
 Low Traction  Dusty  
 Med Traction  Indoor  
 High Traction  Outdoor

### Spring Rate

#50	Black	#68	Blue
#55	Orange	#70	Silver
#60	Orange Yellow	#72	Cobalt Blue
#65	Yellow	#75	Light Green

### Gear Ratio

Secondary Gear Ratio 2.5 (16:40)

	16	17	18	19	20	21	22	23	24	25
76	/	11.18	10.56	10.00	9.50	9.05	8.64	8.26	7.92	7.60
78	12.19	11.47	10.83	10.26	9.75	9.29	8.86	8.48	8.13	7.80

### Shock Piston

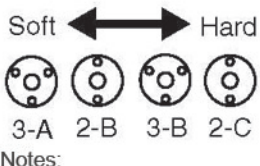

### Sway Bar

1.0	Nickel
1.1	Gold
1.2	Silver
1.3	Copper
1.4	Black
1.5	Golden
1.6	Chromium

### ESC&Battery

ESC: \_\_\_\_\_  
 ESC Setting: \_\_\_\_\_

Battery: \_\_\_\_\_

Battery Position:

- Front  
 Rear

*Be environmental friendly,  
 print only if needed*

*More setups on*

### Comments

\_\_\_\_\_  
 \_\_\_\_\_