

Name: Nick Caro Date: 31st May 2015 Track / City: Bury Event: Regional Rd3

Front Suspension

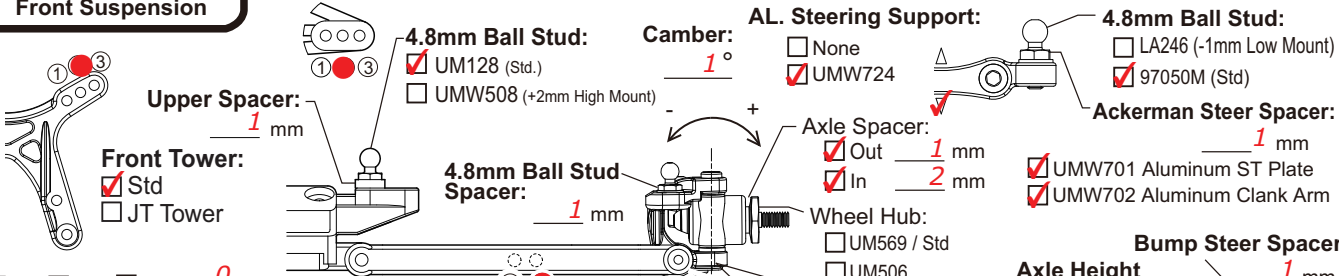

Upper Spacer: 1 mm

4.8mm Ball Stud:
 UM128 (Std.)
 UMW508 (+2mm High Mount)

Front Tower:
 Std
 JT Tower

Toe: In Out 0°

Tie Rod: _____

Front Bulkhead Weight Placement: * 1oz=28g
 None
 Bulkhead Inside _____ oz _____ g
 On the skid plate _____ oz _____ g

4.8mm Ball Stud Spacer: 1 mm

AL. Steering Support:
 None
 UMW724

Axle Spacer:
 Out 1 mm
 In 2 mm

Wheel Hub:
 UM569 / Std
 UM506

4.8mm Ball Stud:
 LA246 (-1mm Low Mount)
 97050M (Std)

Ackerman Steer Spacer: 1 mm

UMW701 Aluminum ST Plate
 UMW702 Aluminum Clank Arm

Bump Steer Spacer: 1 mm

Axle Height Spacer:
 0.75 mm
 0.75 mm

Caster:
 25°
 30°

Spacer: 0.5 1.0 None

Block: 0° 2° 4°

Caster Block Position:
 IN (wide/Std)
 OUT (Narrow)

Comments: Schelle Rack

Wheelbase: F: 1 mm R: 0 mm

Rear Suspension

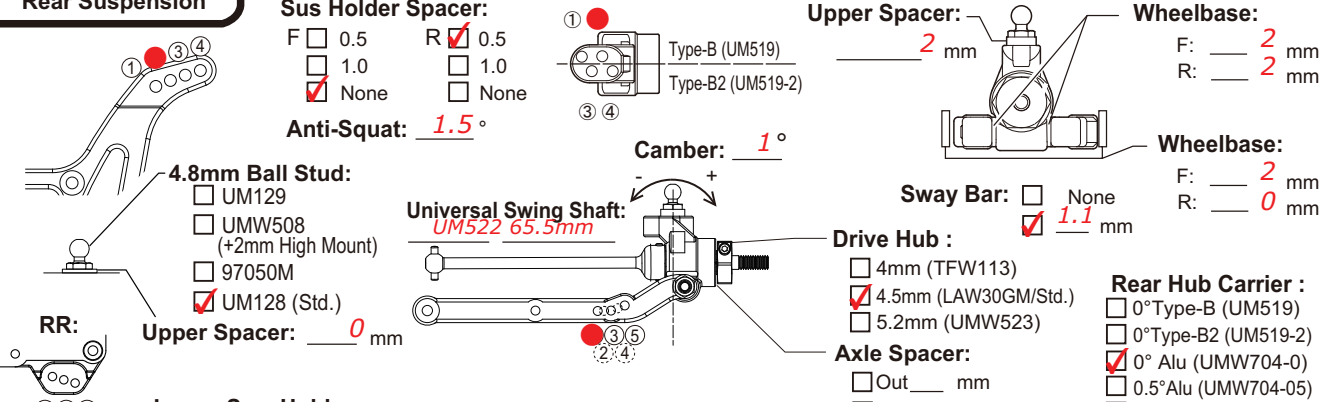

Sus Holder Spacer:
 F: 0.5 1.0 None
 R: 0.5 1.0 None

Anti-Squat: 1.5°

Upper Spacer: 2 mm

4.8mm Ball Stud:
 UM129
 UMW508 (+2mm High Mount)
 97050M
 UM128 (Std.)

RR: 0 mm

Lower Sus. Holder:
 Normal: Narrow RF Wide RF2
 Option: UMW511GM (RF/Alu)

Universal Swing Shaft: UM522 65.5mm

Upper Spacer: 2 mm

Wheelbase: F: 2 mm R: 2 mm

Wheelbase: F: 2 mm R: 0 mm

Sway Bar: None 1.1 mm

Drive Hub:
 4mm (TFW113)
 4.5mm (LAW30GM/Std.)
 5.2mm (UMW523)

Rear Hub Carrier:
 0° Type-B (UM519)
 0° Type-B2 (UM519-2)
 0° Alu (UMW704-0)
 0.5° Alu (UMW704-05)
 1° Alu (UMW704-1)

Axle Spacer:
 Out _____ mm
 In _____ mm

Motor Position:
 Rear Motor
 Midship Motor

Diff.:
 Gear Diff. # _____
 Ball Diff.

Shock

Front **Rear**

Piston: BB 2 Hole (2x1.6mm) BB 2 Hole (2x1.7mm)

Oil: # 35wt # 35wt

Spring: X-Gear YELLOW/H #75 X-Gear RED/MH #72

in	mm	in	mm
out	mm	out	mm

Length(A): 19 mm 28 mm

O-ring: _____

Shock Top type: Alu(UM719/Std) UM753-1

Ball End type: Front: S M L
 Rear: S M L

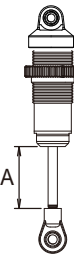

Battery Placement:

UM787 None Screw

Comment: 

Foam:
 Front
 Rear
 None

Battery Type

Straight
 Separate
 Short
 Sideways
 Type: Orion 4000

Chassis

Kit UMW720 (LW)

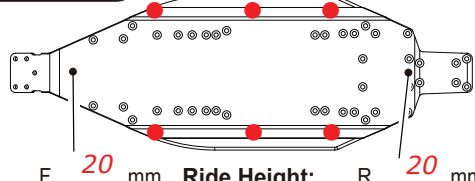

F: 20 mm Ride Height: R: 20 mm

Other

Motor: VST2 7.5
 ESC: Orion R10
 Pinion/Spur: 25 / 76

Truck Condition

Smooth Sandy
 Bumpy Soft Dirt
 Low Truction Grass
 Med. Truction Blue Groove
 Higt Truction Clay
 Wet Dusty
 Dry Astroturf

Wing

Wing Mount: Narrow Wide

Wing Angle: 4° 7° 10°

Blast-S Blast-L
 Step-S Step-M
 Step-L Step 2.0
 Step 3.0
 Straight Lip: UMB03
 Round

Tire

	Front	Rear	Traction Compound or comment:
Tire:	<u>Staggered Rib</u>	<u>Mini Spike</u>	<u>Yellow</u>
Inserts:	<u>Schu Med</u>	<u>Schu Med</u>	<u>Yellow</u>
Wheel:	<u>W5029W</u>	<u>W5202W</u>	

Comment

UM713B arms - 3 deg Rear Toe