

Name _____ Date _____ Track / City _____ Event _____

Front Suspension

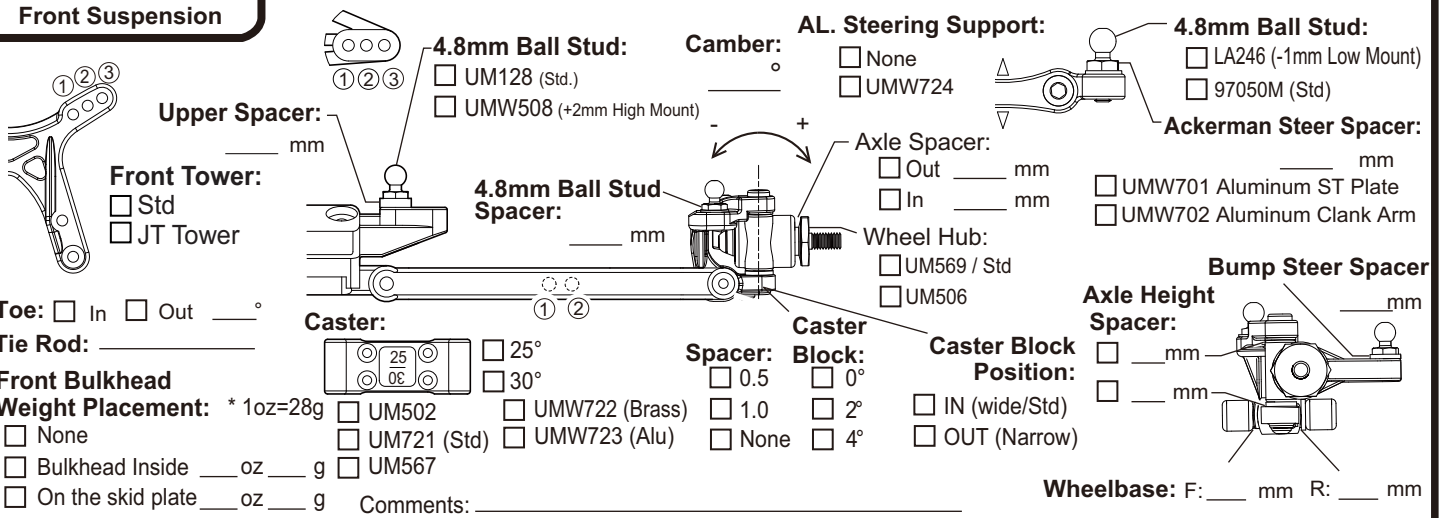

Upper Spacer: _____ mm

Front Tower:
 Std
 JT Tower

Toe: In Out _____°

Tie Rod: _____

Front Bulkhead Weight Placement: * 1oz=28g
 None
 Bulkhead Inside _____ oz _____ g
 On the skid plate _____ oz _____ g

4.8mm Ball Stud:
 UM128 (Std.)
 UMW508 (+2mm High Mount)

4.8mm Ball Stud Spacer: _____ mm

Caster:
 25°
 30°

Caster Block:
 0.5
 1.0
 None

AL. Steering Support:
 None
 UMW724

4.8mm Ball Stud:
 LA246 (-1mm Low Mount)
 97050M (Std.)

Ackerman Steer Spacer: _____ mm
 UMW701 Aluminum ST Plate
 UMW702 Aluminum Clank Arm

Wheel Hub:
 UM569 / Std
 UM506

Wheelbase: F: _____ mm R: _____ mm

Comments: _____

Rear Suspension

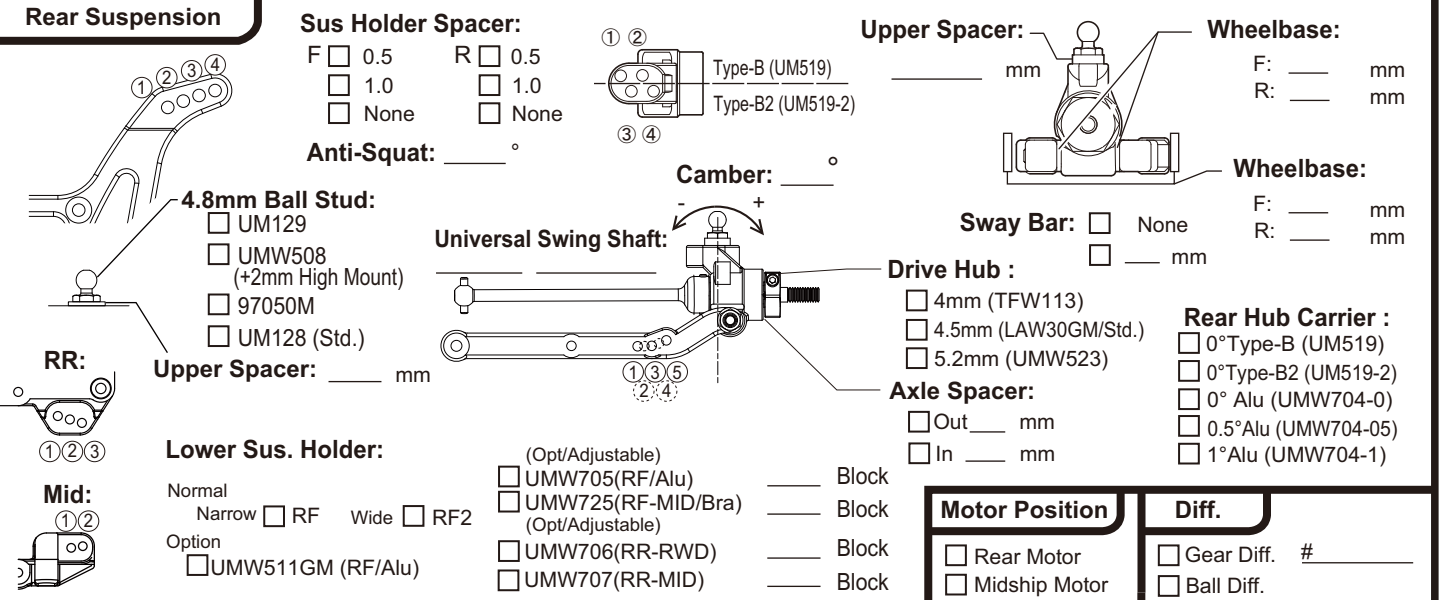

Sus Holder Spacer:
 F 0.5 1.0 None
 R 0.5 1.0 None

Anti-Squat: _____°

4.8mm Ball Stud:
 UM129
 UMW508 (+2mm High Mount)
 97050M
 UM128 (Std.)

Upper Spacer: _____ mm

Lower Sus. Holder:
 Normal
 Narrow RF Wide RF2
 Option UMW511GM (RF/Alu)

Universal Swing Shaft:
 UMW705 (RF/Alu) _____ Block
 UMW725 (RF-MID/Bra) _____ Block (Opt/Adjustable)
 UMW706 (RR-RWD) _____ Block
 UMW707 (RR-MID) _____ Block

Upper Spacer: _____ mm

Wheelbase: F: _____ mm R: _____ mm

Wheelbase: F: _____ mm R: _____ mm

Sway Bar: None _____ mm

Drive Hub:
 4mm (TFW113)
 4.5mm (LAW30GM/Std.)
 5.2mm (UMW523)

Axle Spacer:
 Out _____ mm
 In _____ mm

Rear Hub Carrier:
 0° Type-B (UM519)
 0° Type-B2 (UM519-2)
 0° Alu (UMW704-0)
 0.5° Alu (UMW704-05)
 1° Alu (UMW704-1)

Shock

	Front		Rear	
Piston:	_____	_____	_____	_____
Oil:	# _____	# _____	# _____	# _____
Spring:	_____	_____	_____	_____
Limiters:	in _____ mm	out _____ mm	in _____ mm	out _____ mm
Length(A):	_____ mm		_____ mm	
O-ring:	_____		_____	
Shock Top type:	<input type="checkbox"/> Alu(UM719/Std) <input type="checkbox"/> UM753-1			
Ball End type:	Front: <input type="checkbox"/> S <input type="checkbox"/> M <input type="checkbox"/> L		Rear: <input type="checkbox"/> S <input type="checkbox"/> M <input type="checkbox"/> L	

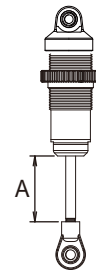

Battery Placement:

UM787 None Screw

Comment: _____

Front Rear

Foam: Front Rear None

Battery Type

Straight
 Separate
 Short
 Sideways

Type: _____

Chassis

Kit UMW720 (LW)

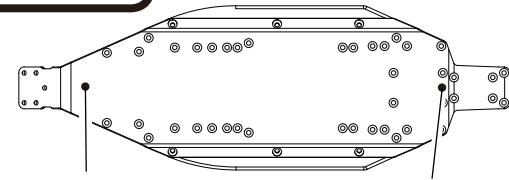

F _____ mm Ride Height: R _____ mm

Other

Motor: _____
 ESC: _____
 Pinion/Spur: _____

Track Condition

- Smooth
- Bumpy
- Low Truction
- Med. Truction
- Higt Truction
- Wet
- Dry
- Sandy
- Soft Dirt
- Grass
- Blue Groore
- Clay
- Dusty
- Astroturf

Wing

- Wing Mount: Narrow Wide
- Wing Angle: 4° 7° 10°
- Lip: Straight Round

Tire

	Front	Rear	Traction Compound or comment:
Tire:	_____	_____	_____
Inserts:	_____	_____	_____
Wheel:	_____	_____	_____

Comment
