

Inferno MP9e Setup Sheet

Arn0 at Petitr.com

ver.1.05

Driver: _____ Date: _____ Event: _____ Track: _____

Track condition: Smooth / Bumpy / Dry / Wet Traction: Low / Medium / High
Blue Groove / Clay / Dirt / Dusty / Grass / Sandy / Loose / Loomy

Motor: _____

ESC: _____

Front tyre: _____ Rear tyre: _____

ESC Setting: _____

Front ride height: _____ Rear ride height: _____

Pinion / Spur: _____

Battery: _____

●ダンパーセッティング / Shock-Set-Up

	FRONT	REAR
ダンパータイプ Shock Type		
ダンパーピストン Shock Piston	<input type="checkbox"/> φ 1.2x6B <input type="checkbox"/> φ 1.2x8B <input type="checkbox"/> φ 1.2x8T <input type="checkbox"/> φ 1.3x5B <input type="checkbox"/> φ 1.3x6W <input type="checkbox"/> φ 1.3x8W <input type="checkbox"/> φ 1.3x8T <input type="checkbox"/> φ 1.4x5W <input type="checkbox"/> φ 1.4x8T	<input type="checkbox"/> φ 1.2x6B <input type="checkbox"/> φ 1.2x8B <input type="checkbox"/> φ 1.2x8T <input type="checkbox"/> φ 1.3x5B <input type="checkbox"/> φ 1.3x6W <input type="checkbox"/> φ 1.3x8W <input type="checkbox"/> φ 1.3x8T <input type="checkbox"/> φ 1.4x5W <input type="checkbox"/> φ 1.4x8T
オイル Oil	#	#
スプリング Spring		
プレッシャースポンジ Pressure Sponge		

B = Black
W = White
T = Taper

●デフセッティング / Diff Gear Set-Up

	FRONT	CENTER	REAR
オイル Oil	<input type="checkbox"/> Normal <input type="checkbox"/> LSD	<input type="checkbox"/> Normal <input type="checkbox"/> LSD	<input type="checkbox"/> Normal <input type="checkbox"/> LSD

●トー角 / Toe Angle

FRONT	REAR
+ °	<input type="checkbox"/> 2° <input type="checkbox"/> 2.5° <input type="checkbox"/> 3°

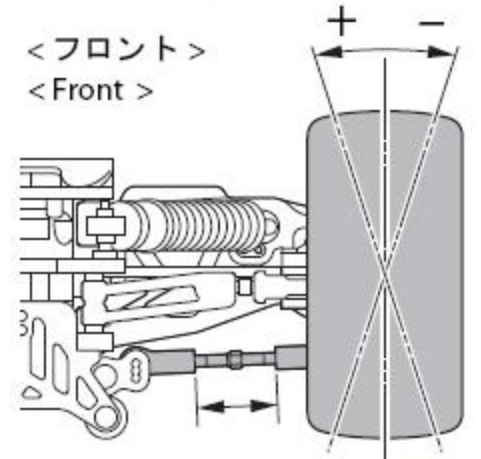

●ホイールベース / Wheelbase

Wheelbase	
リヤハブカラー Collar of Rear Hub	Front Side _____ mm Rear Side _____ mm

●リヤロールセンター&スキッド角 / Rear Roll Center & Skid Angle

< ロールセンターH > < Roll Center H >



< ロールセンターL > < Roll Center L >



●車高 / Ride Height

FRONT	REAR
mm	mm

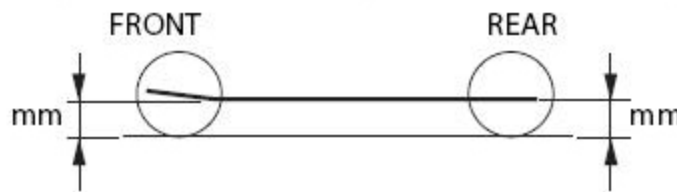

●リバウンド高 / Rebound ●キャンバー角 / Camber Angle

FRONT	REAR
mm	mm

FRONT	REAR
+ °	+ °
- °	- °

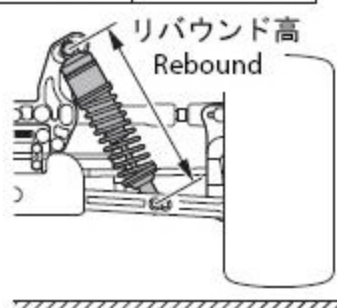

+ Positive Camber
- Negative Camber

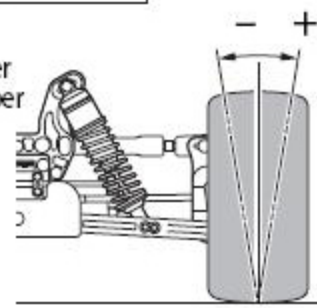

●フロントスキッド角 / Front Skid Angle

上部 Upper	フロント側 Front Side	<input type="checkbox"/> <input type="checkbox"/> <input type="checkbox"/> <input type="checkbox"/> <input type="checkbox"/> <input type="checkbox"/>
	リヤ側 Rear Side	<input type="checkbox"/> <input type="checkbox"/> <input type="checkbox"/>
下部 Under	フロント側 Front Side	<input type="checkbox"/> 9°L <input type="checkbox"/> 11°L <input type="checkbox"/> <input type="checkbox"/> <input type="checkbox"/> <input type="checkbox"/> 9°S <input type="checkbox"/> 11°S <input type="checkbox"/> <input type="checkbox"/> <input type="checkbox"/>

●アッパーアームポジション / Upper Arm Position

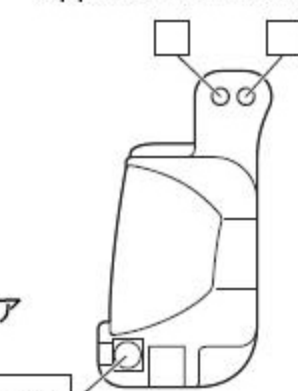

●フロントトレッド / Front Tread

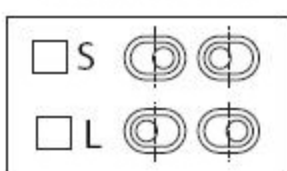

●フロントハブキャリア / Front Hub Carrier

<input type="checkbox"/> -1° <input type="checkbox"/> 0° <input type="checkbox"/> +1°
<input type="checkbox"/> Plastic
<input type="checkbox"/> Aluminum

●ダンパー取り付け位置 / Shock Mount Position

上部 / Shock Stay		下部 / Sus Arm	
FRONT	REAR	FRONT	REAR
<input type="checkbox"/> In <input type="checkbox"/> Out	<input type="checkbox"/> In <input type="checkbox"/> Out	<input type="checkbox"/> In <input type="checkbox"/> Out	<input type="checkbox"/> In <input type="checkbox"/> Out
Rear Shock Stay		<input type="checkbox"/> SHORT	<input type="checkbox"/> LONG

●アッパーアームポジション / Upper Arm Position

	REAR
パルク側 Shock Stay	<input type="checkbox"/> 1 <input type="checkbox"/> 2 <input type="checkbox"/> 3 <input type="checkbox"/> 4 <input type="checkbox"/> 5 <input type="checkbox"/> 6 <input type="checkbox"/> 7 <input type="checkbox"/> 8
ホイール側 Wheel side	<input type="checkbox"/> 1 <input type="checkbox"/> 2 <input type="checkbox"/> 3 <input type="checkbox"/> 4 ※ 3, 4は1FW410使用時

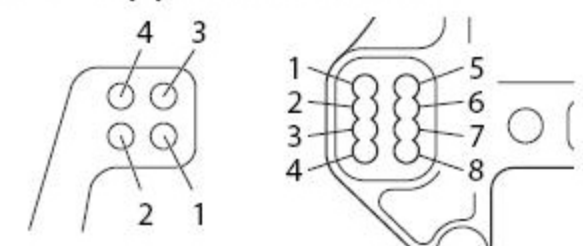

●リヤハブキャリア / Rear Hub Carrier

<input type="checkbox"/> Plastic <input type="checkbox"/> Hard
<input type="checkbox"/> Aluminum
<input type="checkbox"/> Aluminum / Off-2.0

●ステアリングプレート / Steering Plate

<input type="checkbox"/> A	<input type="checkbox"/> F↑
<input type="checkbox"/> B	
<input type="checkbox"/> C	<input type="checkbox"/> F↓

●リヤハブポジション / Rear Hub Position

<input type="checkbox"/> Upper	<input type="checkbox"/> Under
--------------------------------	--------------------------------

●トルクロッド / Chassis Brace

FRONT	REAR
<input type="checkbox"/> Plastic	<input type="checkbox"/> Plastic
<input type="checkbox"/> Aluminum	<input type="checkbox"/> Aluminum

●スタビライザー / Anti Roll Bar

FRONT	REAR
φ	φ
mm	mm

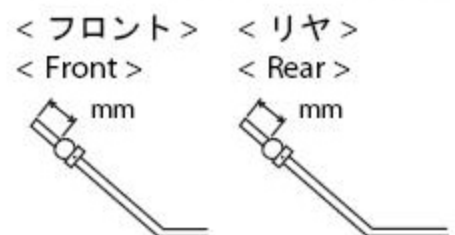

●リヤトレッド / Rear Tread

フロント側 Front Side	リヤ側 Rear Side
<input type="checkbox"/> S <input type="checkbox"/> M <input type="checkbox"/> L	<input type="checkbox"/> S <input type="checkbox"/> M <input type="checkbox"/> L

●ウイング角度 / Wing Angle

<input type="checkbox"/> Upper	<input type="checkbox"/> Under
--------------------------------	--------------------------------

●ホイールハブ / Wheel Hub

FRONT	REAR
<input type="checkbox"/> NARROW	<input type="checkbox"/> NARROW
<input type="checkbox"/> NORMAL	<input type="checkbox"/> NORMAL

●ウエイト / Weight

--