

J-CONCEPTS BJ4 SET-UP SHEET:

DRIVER: RYAN CAVALIERI

DATE: APRIL 10, 2005

TRACK/CITY: LAKE PARK / TAMPA

EVENT: LOSI OFF-ROAD CHAMPS

NOTES:

1. REAR SWAY BAR KIT (.055" WIRE STANDARD)
2. BONES LEVEL IN REAR, ARMS SLIGHTLY BELOW LEVEL IN FRONT
3. EXTRA CHASSIS WEIGHT NEXT TO MOTOR (3/4 OZ.)
4. ILLUZION HD WING CUT DOWN IN THE BACK TO THE SECOND CUT LINE

2005 LOSI OFF-ROAD CHAMPS
TQ AND 1ST PLACE.



CONDITIONS:

- SMOOTH: X
- BUMPY: _____
- LOW TRACTION: _____
- MED TRACTION: _____
- HIGH TRACTION: X
- WET: _____
- DRY: X
- SANDY: _____
- SOFT DIRT: _____
- GRASS: _____
- BLUE GROOVE: X
- CLAY: _____
- DUSTY: _____
- OTHER: _____

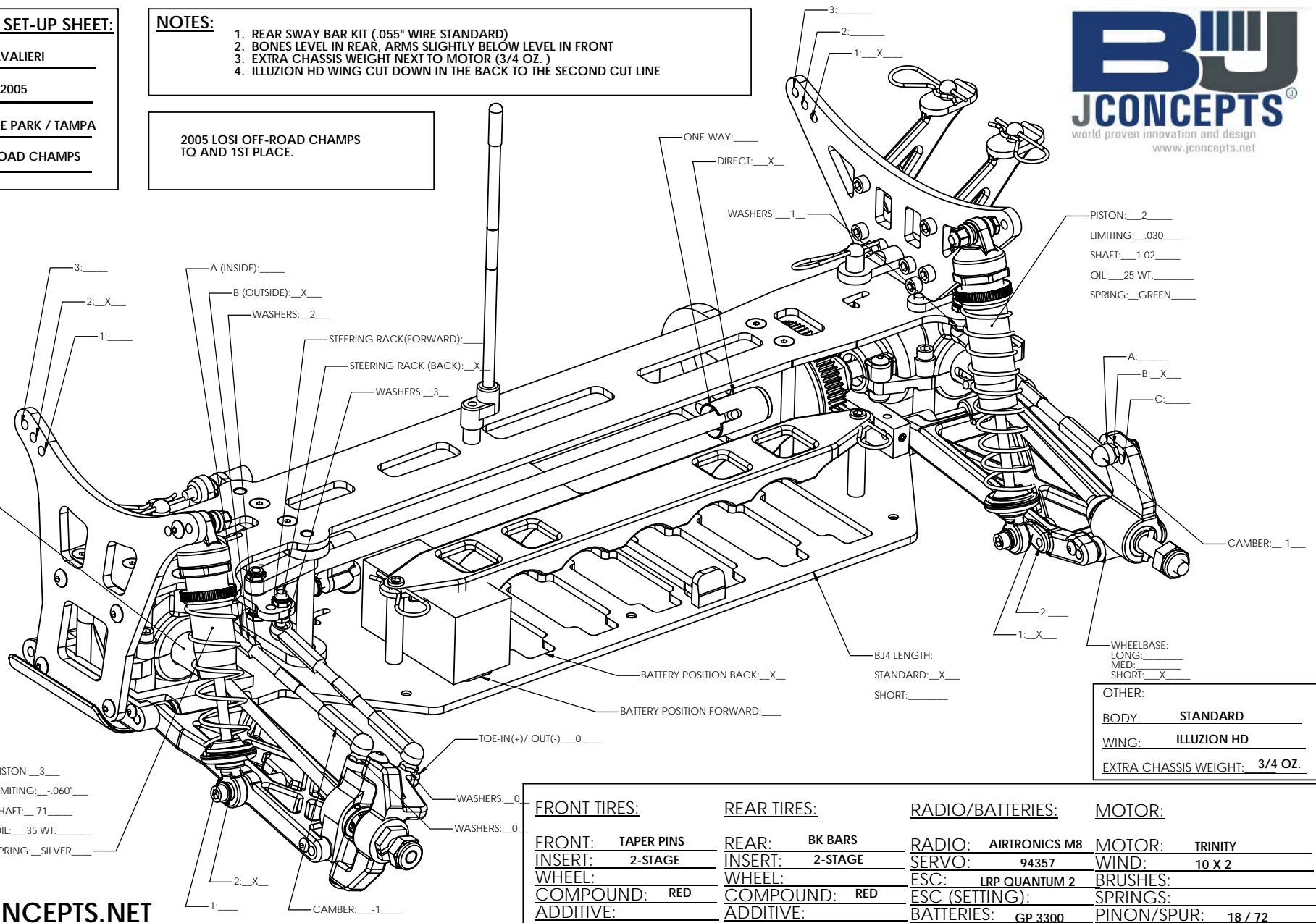

WWW.JCONCEPTS.NET

FRONT TIRES:

FRONT: TAPER PINS
 INSERT: 2-STAGE
 WHEEL: _____
 COMPOUND: RED
 ADDITIVE: _____

REAR TIRES:

REAR: BK BARS
 INSERT: 2-STAGE
 WHEEL: _____
 COMPOUND: RED
 ADDITIVE: _____

RADIO/BATTERIES:

RADIO: AIRTRONICS M8
 SERVO: 94357
 ESC: LRP QUANTUM 2
 ESC (SETTING): _____
 BATTERIES: GP 3300

MOTOR:

MOTOR: TRINITY
 WIND: 10 X 2
 BRUSHES: _____
 SPRINGS: _____
 PINON/SPUR: 18 / 72