

**J-CONCEPTS BJ4 SET-UP SHEET:**

**DRIVER:** RYAN CAVALIERI  
**DATE:** JUNE 11, 2005  
**TRACK/CITY:** COLLEGNO, ITALY  
**EVENT:** WORLDS WARM-UP

**NOTES:** TRACK CONDITIONS WERE EXTREMELY BUMPY, DUSTY AND CHOPPY. RACERS EDGE 5 DEGREE REAR HUBS WERE ADDED FOR EXTRA REAR TOE-IN. 1 WASHER WAS USED ON THE B HOLE LOCATION.

**NOTES:** SWAY BAR KIT WAS USED WITH STANDARD .055" WIRE.



- CONDITIONS:**
- SMOOTH: \_\_\_\_\_
  - BUMPY:  X
  - LOW TRACTION:  X
  - MED TRACTION: \_\_\_\_\_
  - HIGH TRACTION: \_\_\_\_\_
  - WET: \_\_\_\_\_
  - DRY:  X
  - SANDY:  X
  - SOFT DIRT: \_\_\_\_\_
  - GRASS: \_\_\_\_\_
  - BLUE GROOVE: \_\_\_\_\_
  - CLAY: \_\_\_\_\_
  - DUSTY:  X
  - OTHER: CHOPPY

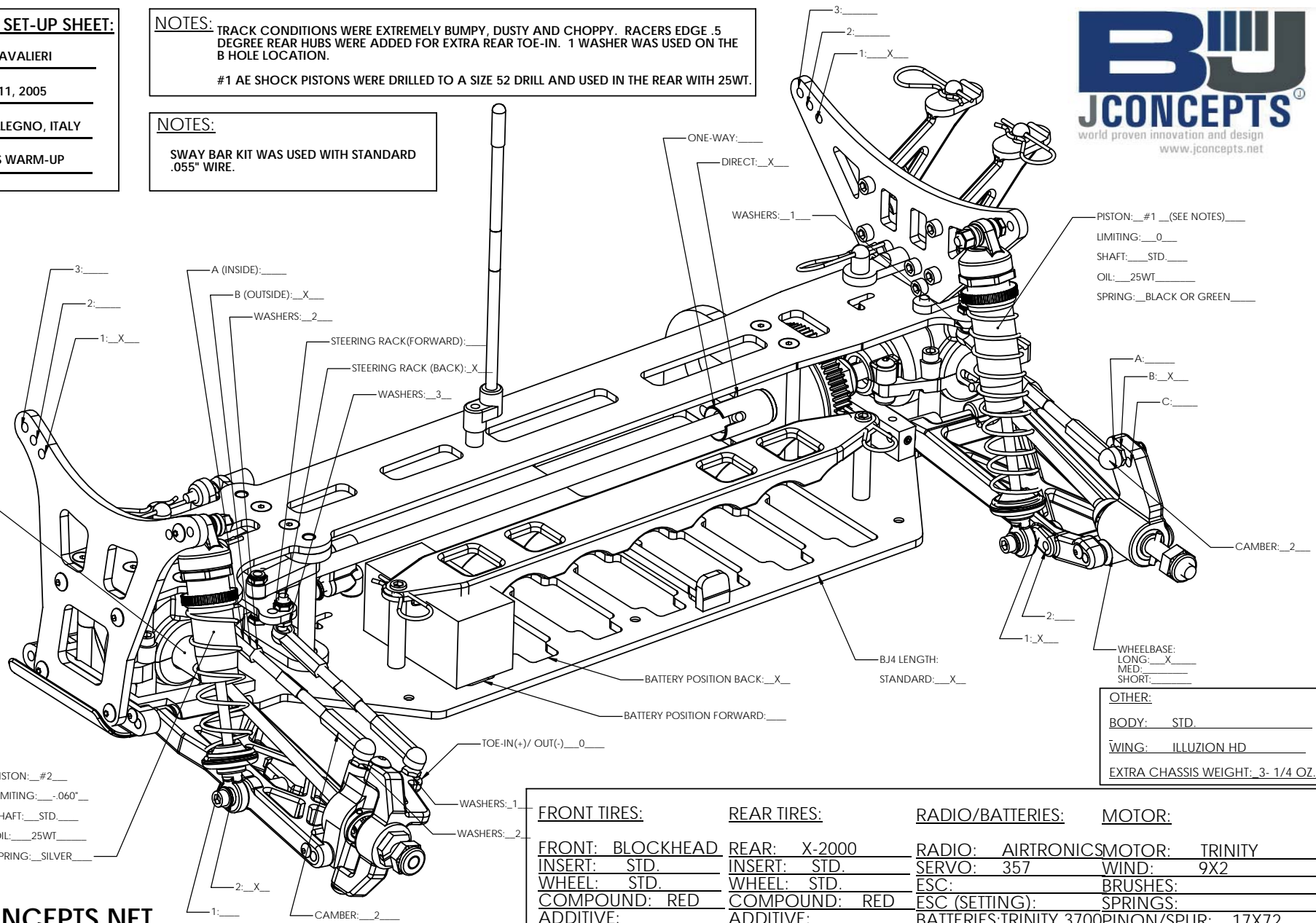

PISTON: #1 (SEE NOTES) \_\_\_\_\_  
 LIMITING: 0 \_\_\_\_\_  
 SHAFT: STD \_\_\_\_\_  
 OIL: 25WT \_\_\_\_\_  
 SPRING: BLACK OR GREEN \_\_\_\_\_

WHEELBASE:  
 LONG:  X  
 MED: \_\_\_\_\_  
 SHORT: \_\_\_\_\_

**OTHER:**  
 BODY: STD \_\_\_\_\_  
 WING: ILLUZION HD \_\_\_\_\_  
 EXTRA CHASSIS WEIGHT: 3- 1/4 OZ \_\_\_\_\_

PISTON: #2 \_\_\_\_\_  
 LIMITING: .060" \_\_\_\_\_  
 SHAFT: STD \_\_\_\_\_  
 OIL: 25WT \_\_\_\_\_  
 SPRING: SILVER \_\_\_\_\_

FRONT TIRES:	REAR TIRES:	RADIO/BATTERIES:	MOTOR:
FRONT: BLOCKHEAD	REAR: X-2000	RADIO: AIRTRONICS	MOTOR: TRINITY
INSERT: STD	INSERT: STD	SERVO: 357	WIND: 9X2
WHEEL: STD	WHEEL: STD	ESC:	BRUSHES:
COMPOUND: RED	COMPOUND: RED	ESC (SETTING):	SPRINGS:
ADDITIVE:	ADDITIVE:	BATTERIES: TRINITY 3700	PINON/SPUR: 17X72