

J-CONCEPTS BJ4 SET-UP SHEET:

DRIVER: RICHARD LOWE / TOM COCKERILL

DATE: 6/21/05

TRACK/CITY: BURY

EVENT: BRCA SERIES EVENT

NOTES:

REAR SHOCK PISTON USED WAS #3 ASSOCIATED WITH AN ADDITIONAL HOLE DRILLED. HOLE DRILLED MATCHED OTHER 2 HOLES.



CONDITIONS:

- SMOOTH: _____
- BUMPY: _____
- LOW TRACTION: _____
- MED TRACTION: _____
- HIGH TRACTION: X
- WET: _____
- DRY: _____
- SANDY: _____
- SOFT DIRT: _____
- GRASS: X
- BLUE GROOVE: _____
- CLAY: _____
- DUSTY: _____
- OTHER: _____

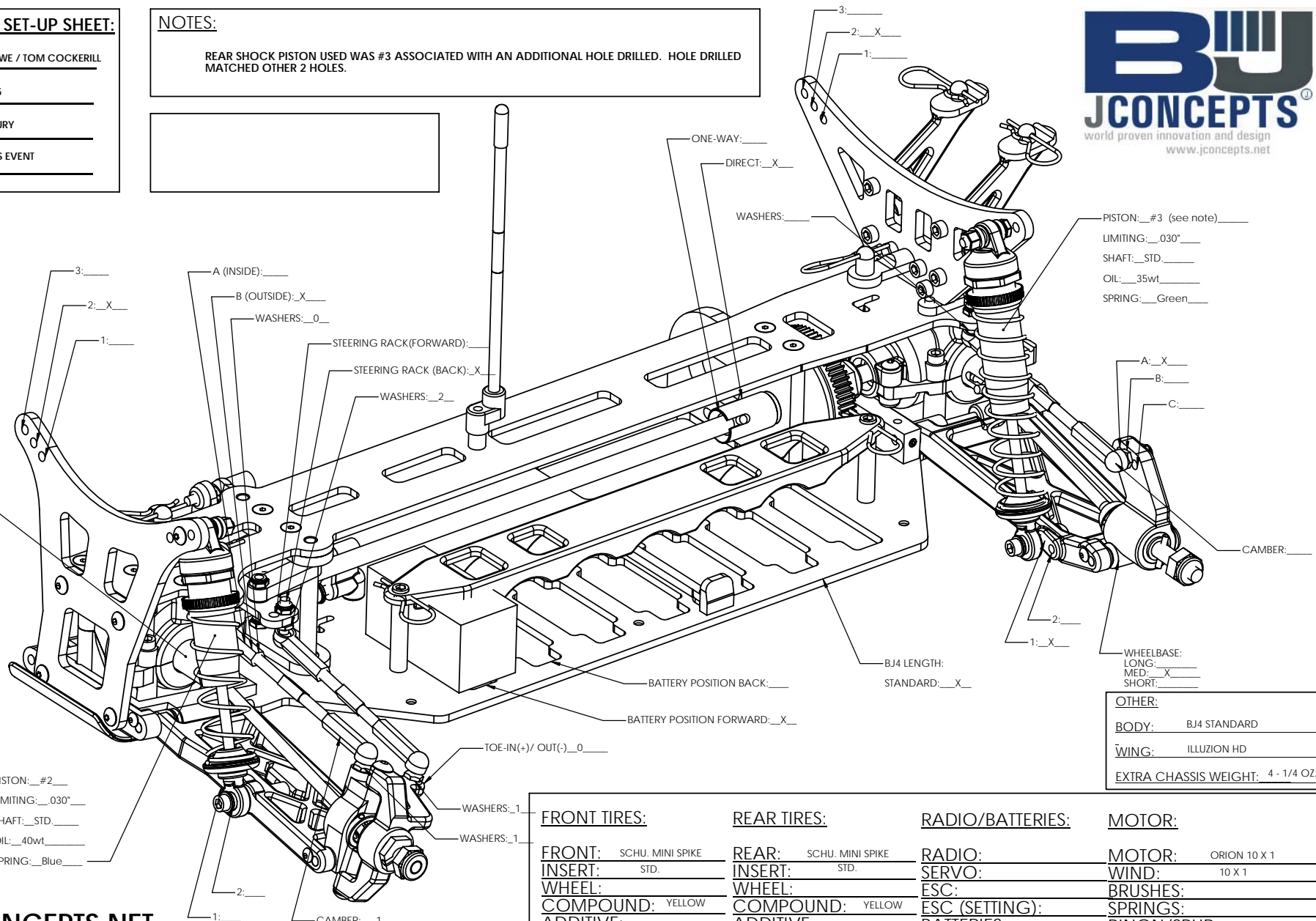

WWW.JCONCEPTS.NET

OTHER:

BODY: BJ4 STANDARD

WING: ILLUZION HD

EXTRA CHASSIS WEIGHT: 4 - 1/4 OZ.

FRONT TIRES:	REAR TIRES:	RADIO/BATTERIES:	MOTOR:
FRONT: SCHU. MINI SPIKE	REAR: SCHU. MINI SPIKE	RADIO: _____	MOTOR: ORION 10 X 1
INSERT: STD.	INSERT: STD.	SERVO: _____	WIND: 10 X 1
WHEEL: _____	WHEEL: _____	ESC: _____	BRUSHES: _____
COMPOUND: YELLOW	COMPOUND: YELLOW	ESC (SETTING): _____	SPRINGS: _____
ADDITIVE: _____	ADDITIVE: _____	BATTERIES: _____	PINON/SPUR: 18 X 72