

J-CONCEPTS BJ4 SET-UP SHEET:

DRIVER: Mark Pavidis
DATE: July 2004
TRACK/CITY: New Mexico
EVENT: ROAR Nationals

CONDITIONS:

SMOOTH: X
 BUMPY: _____
 LOW TRACTION: _____
 MED TRACTION: _____
 SUPER HIGH TRACTION: X
 WET: _____
 DRY: _____
 SANDY: _____
 SOFT DIRT: _____
 GRASS: _____
 BLUE GROOVE: X
 CLAY: _____
 DUSY: _____
 OTHER: Track= sandpaper finish

NOTES:

Sway Bar kit installed. All washers are .030" unless otherwise specified. Heavy Duty front arms. Holes reamed in the scoops of the body for extra cooling flow to motor. Ride height arms level all the way around. Direct shaft kit was used for full time 4wd for extra braking control. Tip: Lower ride height when track has extra grip. Handout tires at the nationals was not an ideal balance. Matching thread patterns and or compounds is preferred at all times.

1. For extra traction try using Racers Edge .5 or 1 degree hub carriers.
2. Weight was added to the right side of the chassis near the motor for better balance.

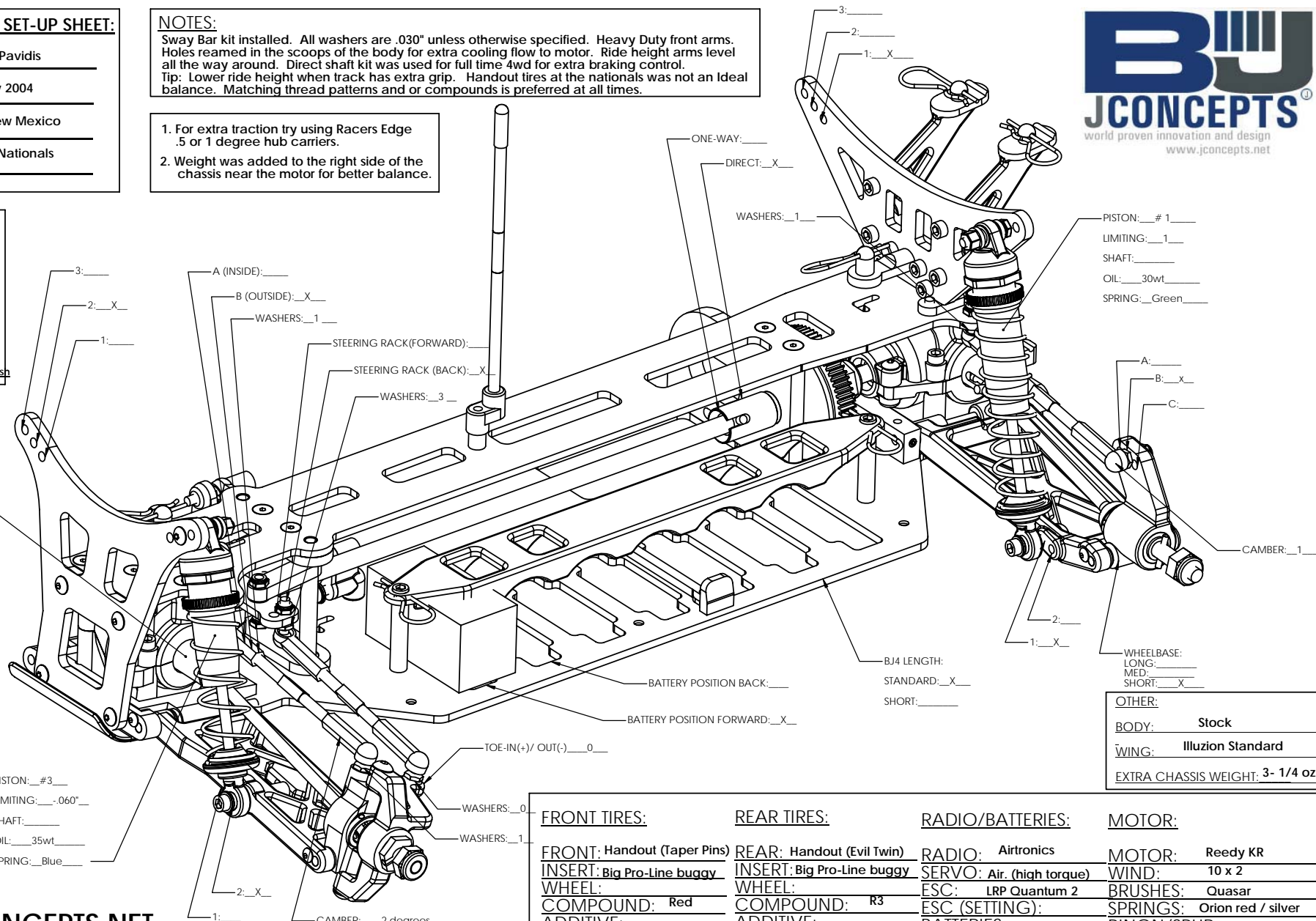

PISTON: # 1
 LIMITING: 1
 SHAFT: _____
 OIL: 30wt
 SPRING: Green

A: _____
 B: x
 C: _____

WHEELBASE:
 LONG: _____
 MED: _____
 SHORT: X

OTHER:
 BODY: Stock
 WING: Illuzion Standard
 EXTRA CHASSIS WEIGHT: 3- 1/4 oz.

PISTON: #3
 LIMITING: .060"
 SHAFT: _____
 OIL: 35wt
 SPRING: Blue

FRONT TIRES:	REAR TIRES:	RADIO/BATTERIES:	MOTOR:
FRONT: Handout (Taper Pins)	REAR: Handout (Evil Twin)	RADIO: Airtronics	MOTOR: Reedy KR
INSERT: Big Pro-Line buggy	INSERT: Big Pro-Line buggy	SERVO: Air. (high torque)	WIND: 10 x 2
WHEEL: _____	WHEEL: _____	ESC: LRP Quantum 2	BRUSHES: Quasar
COMPOUND: Red	COMPOUND: R3	ESC (SETTING): _____	SPRINGS: Orion red / silver
ADDITIVE: _____	ADDITIVE: _____	BATTERIES: Reedy 3300	PINON/SPUR: 16 x 72