

J-CONCEPTS BJ4 SET-UP SHEET:

DRIVER: JR Mitch
DATE: 10-19-04
TRACK/CITY: Minnreg, Ocala
EVENT: Regional events

NOTES:

Sway Bar Kit added (stock .055" bar). All washers are .030" unless otherwise specified.
 Heavy duty front arms. Holes reamed in the scoops of the body for extra cooling flow to motor.
 Ride height arms level all the way around.
 Shaft one-way used and AE NTC3 heavy duty front one-way.
 Added Reedy Cooling fan to motor area.

1. For extra traction try using Racers Edge .5 or 1 degree hub carriers.
2. Weight was added to the right side of the chassis near the motor for better balance.

CONDITIONS:

SMOOTH: X
 BUMPY: X
 LOW TRACTION:
 MED TRACTION: X
 HIGH TRACTION: X
 WET: X
 DRY:
 SANDY: X
 SOFT DIRT:
 GRASS:
 BLUE GROOVE: X
 CLAY:
 DUSTY:
 OTHER:

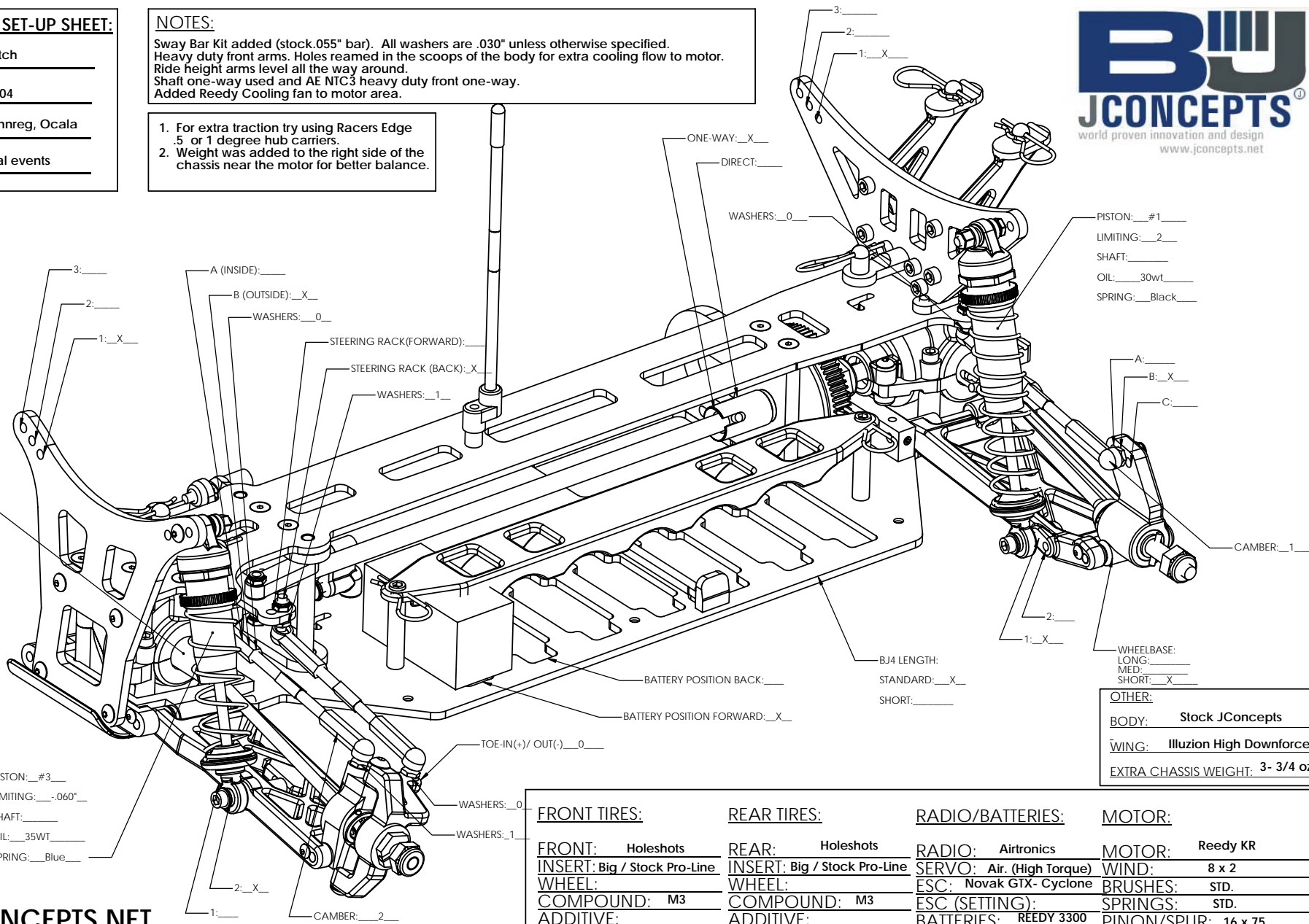

OTHER:
 BODY: Stock JConcepts
 WING: Illuzion High Downforce
 EXTRA CHASSIS WEIGHT: 3- 3/4 oz.

FRONT TIRES:	REAR TIRES:	RADIO/BATTERIES:	MOTOR:
FRONT: Holeshots	REAR: Holeshots	RADIO: Airtronics	MOTOR: Reedy KR
INSERT: Big / Stock Pro-Line	INSERT: Big / Stock Pro-Line	SERVO: Air. (High Torque)	WIND: 8 x 2
WHEEL:	WHEEL:	ESC: Novak GTX- Cyclone	BRUSHES: STD.
COMPOUND: M3	COMPOUND: M3	ESC (SETTING):	SPRINGS: STD.
ADDITIVE:	ADDITIVE:	BATTERIES: REEDY 3300	PINON/SPUR: 16 x 75