

J-CONCEPTS BJ4 SET-UP SHEET:

DRIVER: Al Horne
DATE: August - October 2004
TRACK/CITY: Michigan
EVENT: Regional events

CONDITIONS:
 SMOOTH: _____
 BUMPY: X
 LOW TRACTION: _____
 MED TRACTION: X
 HIGH TRACTION: _____
 WET: X
 DRY: _____
 SANDY: X
 SOFT DIRT: X
 GRASS: _____
 BLUE GROOVE: _____
 CLAY: _____
 DUSTY: _____
 OTHER: Loamy

NOTES:

No Sway Bar Kit. All washers are .030" unless otherwise specified. Heavy duty front arms. Holes reamed in the scoops of the body for extra cooling flow to motor. Ride height arms level all the way around. Direct shaft kit was used for full time 4wd for extra braking control. Shaft one-way is used on tracks with higher loamy grip. Front springs are cut AE truck silver fronts (total 6 coils)

1. For extra traction try using Racers Edge .5 or 1 degree hub carriers.
2. Weight was added to the right side of the chassis near the motor for better balance.

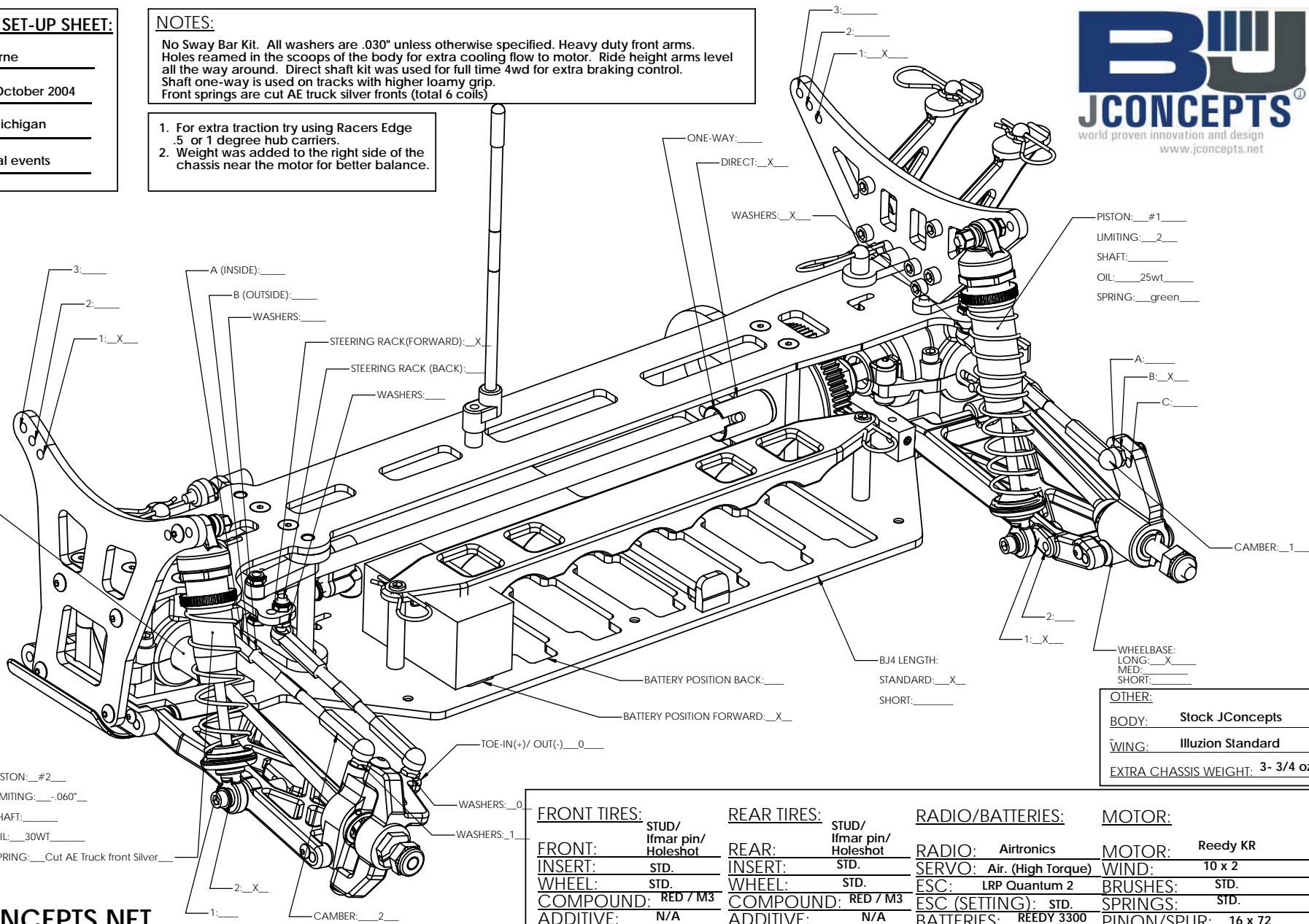

PISTON: #1
 LIMITING: 2
 SHAFT: _____
 OIL: 25wt
 SPRING: green

A: _____
 B: X
 C: _____
 CAMBER: 1

WHEELBASE:
 LONG: X
 MED: _____
 SHORT: _____

OTHER:
 BODY: Stock JConcepts
 WING: Illuzion Standard
 EXTRA CHASSIS WEIGHT: 3- 3/4 oz.

PISTON: #2
 LIMITING: .060"
 SHAFT: _____
 OIL: 30WT
 SPRING: Cut AE Truck front Silver

FRONT TIRES:	REAR TIRES:	RADIO/BATTERIES:	MOTOR:
STUD/ l/mar pin/ Hoeshot	STUD/ l/mar pin/ Hoeshot	Airtronics	Reedy KR
FRONT: STD.	REAR: STD.	SERVO: Air. (High Torque)	MOTOR: 10 x 2
INSERT: STD.	INSERT: STD.	ESC: LRP Quantum 2	WIND: STD.
WHEEL: STD.	WHEEL: STD.	ESC (SETTING): STD.	BRUSHES: STD.
COMPOUND: RED / M3	COMPOUND: RED / M3	BATTERIES: REEDY 3300	SPRINGS: STD.
ADDITIVE: N/A	ADDITIVE: N/A		PINON/SPUR: 16 x 72