

BJ4 WORLDS EDITION SET-UP SHEET:

DRIVER _____

DATE _____

TRACK/CITY _____

EVENT _____

NOTES:



TRACK CONDITIONS:

SOFT SURFACES:	HARD SURFACES:
SAND / SOIL _____	WET _____
LOAMY _____	HARD SLICK _____
RUTS _____	ABRASIVE _____
WET _____	BLUE GROOVE _____
DRY _____	BLACK GROOVE _____
	BROKEN _____

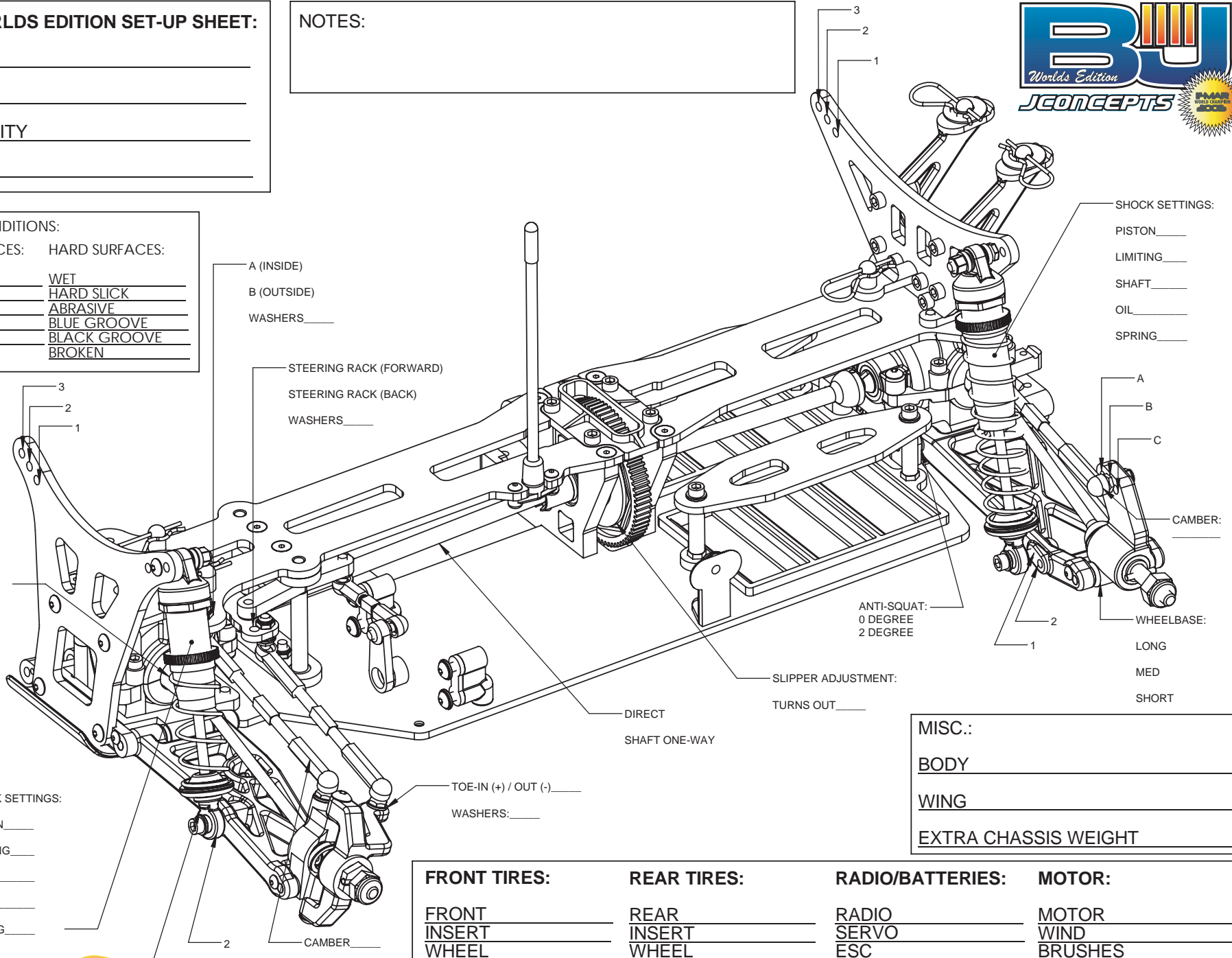

SHOCK SETTINGS:
 PISTON _____
 LIMITING _____
 SHAFT _____
 OIL _____
 SPRING _____

CAMBER:

 WHEELBASE:
 LONG _____
 MED _____
 SHORT _____

ONE-WAY
DIFF

ANTI-SQUAT:
 0 DEGREE _____
 2 DEGREE _____

SLIPPER ADJUSTMENT:
 TURNS OUT _____

SHOCK SETTINGS:
 PISTON _____
 LIMITING _____
 SHAFT _____
 OIL _____
 SPRING _____

TOE-IN (+) / OUT (-) _____
 WASHERS: _____

MISC.:
 BODY _____
 WING _____
 EXTRA CHASSIS WEIGHT _____

FRONT TIRES:	REAR TIRES:	RADIO/BATTERIES:	MOTOR:
FRONT _____	REAR _____	RADIO _____	MOTOR _____
INSERT _____	INSERT _____	SERVO _____	WIND _____
WHEEL _____	WHEEL _____	ESC _____	BRUSHES _____
COMPOUND _____	COMPOUND _____	ESC (SETTING) _____	SPRINGS _____
ADDITIVE _____	ADDITIVE _____	BATTERIES _____	PINON/SPUR _____

